

8

7

6

5

4

3

2

1

F

E

D

C

B

A

F

E

D

C

B

A

REVISIONS				
ZONE	REV.	DESCRIPTION	DATE	APPROVED
	A	CHECK-IN	10/31/2012	MAM
	B	CONFIGURATIONS ADDED FOR 2", .5" .125", & .0315" GAUGE PINS	6/2/2023	CJM

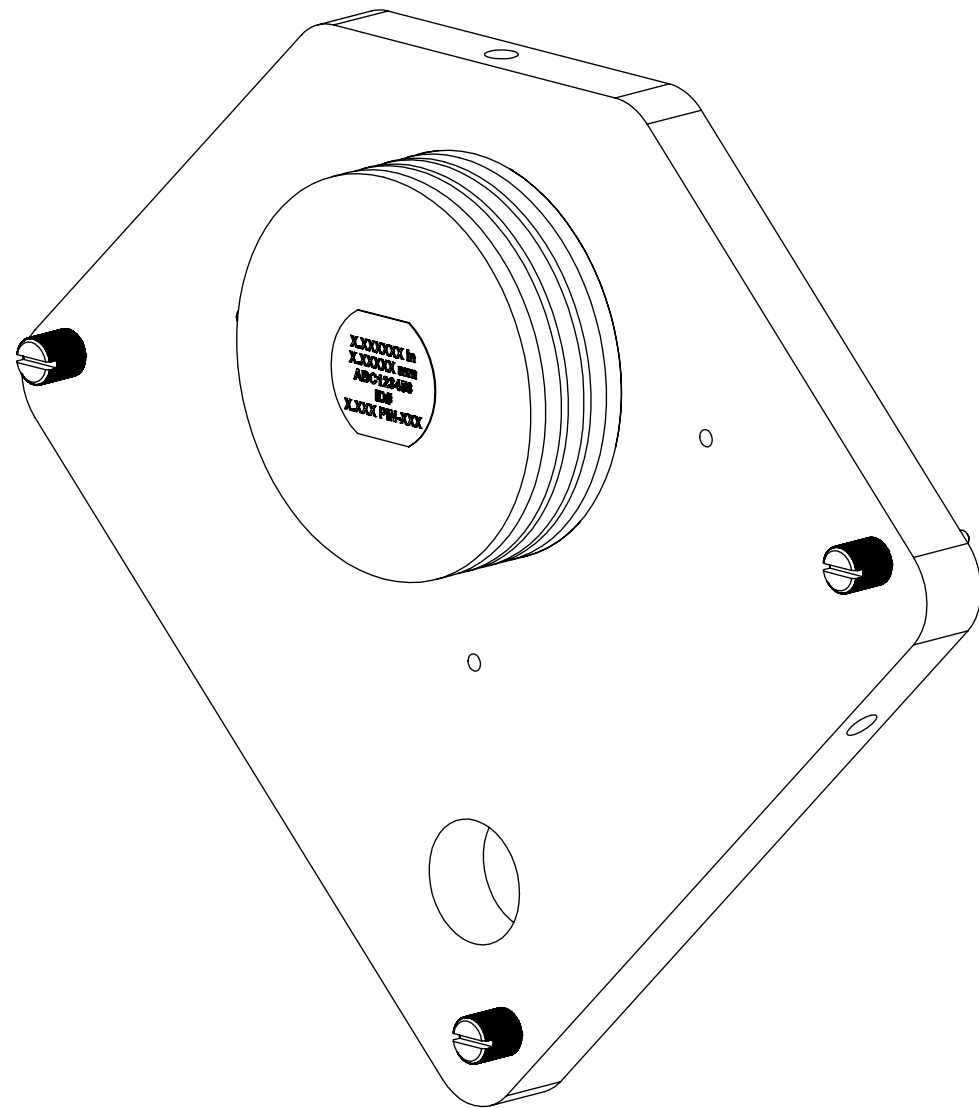

ADVANCED CALIBRATION STANDARDS FOR TRION360 GAUGE

INDEX

- (1) COVER PAGE
- (2) BOM TABLE
- (3) ASSEMBLE CALIBRATION FIXTURE
- (4) 2" CONFIGURATION
- (5) .5" CONFIGURATION
- (6) .125" CONFIGURATION
- (7) .0315" CONFIGURATION
- (8) MOUNT CALIBRATION FIXTURE
- (9) FIXTURE OVERALLS
- (10) 360 MOUNTED OVERALLS

GENERAL FINISH NOTE		UNLESS OTHERWISE SPECIFIED:		NAME	DATE
DE-BURR AND BREAK		DIMENSIONS ARE IN INCHES		DRAWN BY:	EMM
ALL SHARP EDGES		TOLERANCES:			12/04/2020
BEFORE FINISH AND/OR SHIPPING		ANGLES ±.25°			
		TWO PLACE DECIMAL ±0.010			
		THREE PLACE DECIMAL ±0.005			
		FOUR PLACE DECIMAL ±0.0005			
		UNMARKED FILLETS/CHAMFER .06			
		DE-BURR ALL PARTS			
PROPRIETARY AND CONFIDENTIAL		INTERPRET GEOMETRIC TOLERANCING PER: ASME Y14.5			
THE INFORMATION CONTAINED IN THIS DRAWING IS THE SOLE PROPERTY OF LASERLINC, INC. ANY REPRODUCTION IN PART OR AS A WHOLE WITHOUT THE WRITTEN PERMISSION OF LASERLINC, INC. IS PROHIBITED.		MATERIAL		63 RA SURFACE FINISH ALL FEATURES MUST MEET SPECIFICATION AFTER PLATING BEFORE POWDER-COAT IF PLATED OR POWDER-COATED SEE FINISH	
		FINISH			
		DO NOT SCALE DRAWING			
		TITLE:		ADVANCED CALIBRATION STANDARDS FOR TRION360 GAUGE	
		SIZE	DWG. NO.	REV	
		B	0360-0000-34	B	
		SCALE: 1:1		SHEET 1 OF 10	



8

7

6

5

4

3

2

1

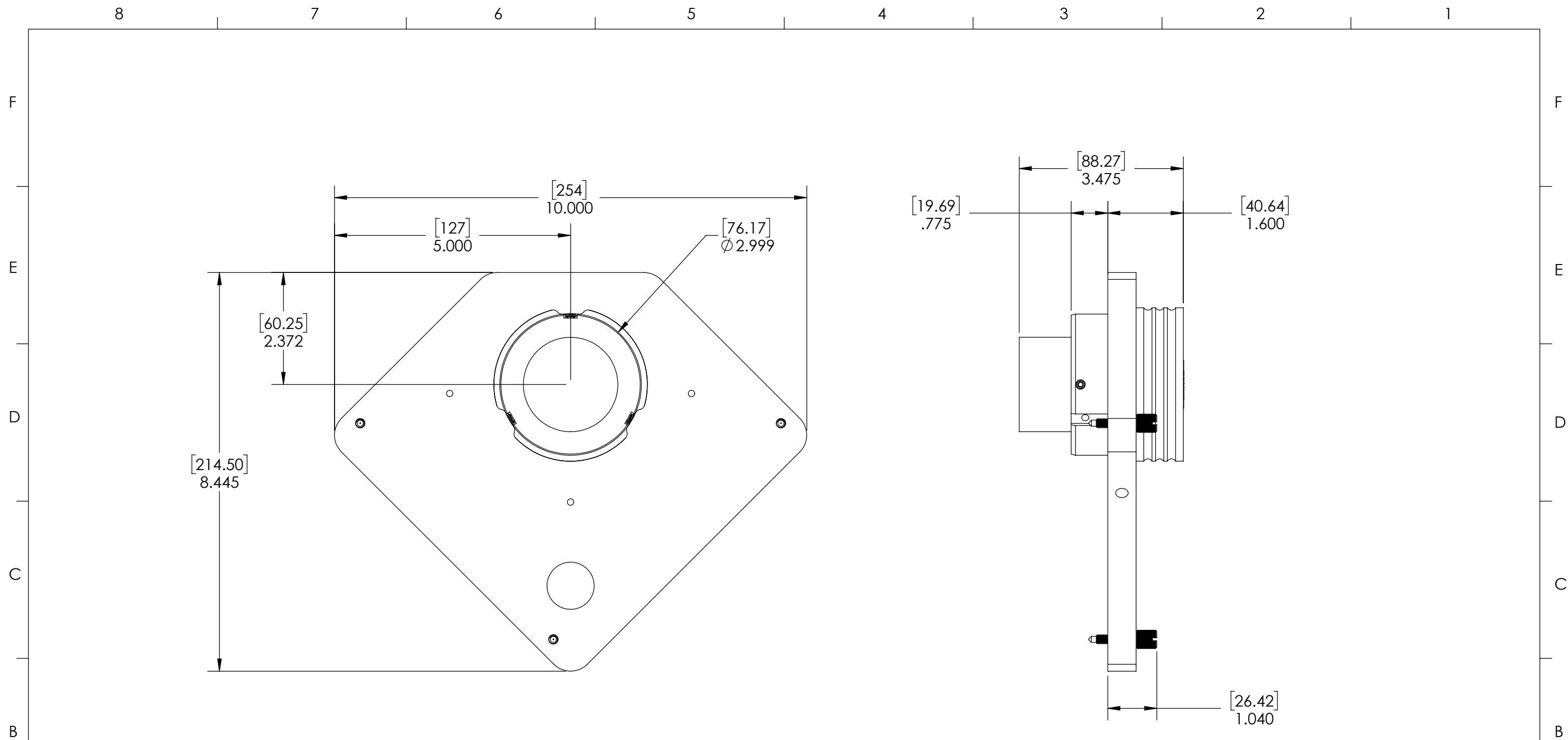

GENERAL FINISH NOTE		UNLESS OTHERWISE SPECIFIED:		NAME	DATE
DE-BURR AND BREAK ALL SHARP EDGES BEFORE FINISH AND/OR SHIPPING		DIMENSIONS ARE IN INCHES TOLERANCES: ANGLES ±.25° TWO PLACE DECIMAL ±0.010 THREE PLACE DECIMAL ±0.005 FOUR PLACE DECIMAL ±0.0005 UNMARKED FILLETS/CHAMFER .06 DE-BURR ALL PARTS		DRAWN BY:	EMM 12/04/2020
PROPRIETARY AND CONFIDENTIAL		INTERPRET GEOMETRIC TOLERANCING PER: ASME Y14.5		TITLE: 0360-0000-34	
THE INFORMATION CONTAINED IN THIS DRAWING IS THE SOLE PROPERTY OF LASERLINC, INC. ANY REPRODUCTION IN PART OR AS A WHOLE WITHOUT THE WRITTEN PERMISSION OF LASERLINC, INC. IS PROHIBITED.		MATERIAL		63 RA SURFACE FINISH ALL FEATURES MUST MEET SPECIFICATION AFTER PLATING BEFORE POWDER-COAT IF PLATED OR POWDER-COATED SEE FINISH	
		FINISH		SIZE B	DWG. NO. 0360-0000-34
		DO NOT SCALE DRAWING		REV B	SHEET 9 OF 10

LASERLINC, INC.
 PHONE: 888-707-4892
 INFO@LASERLINC.COM
 WWW.LASERLINC.COM

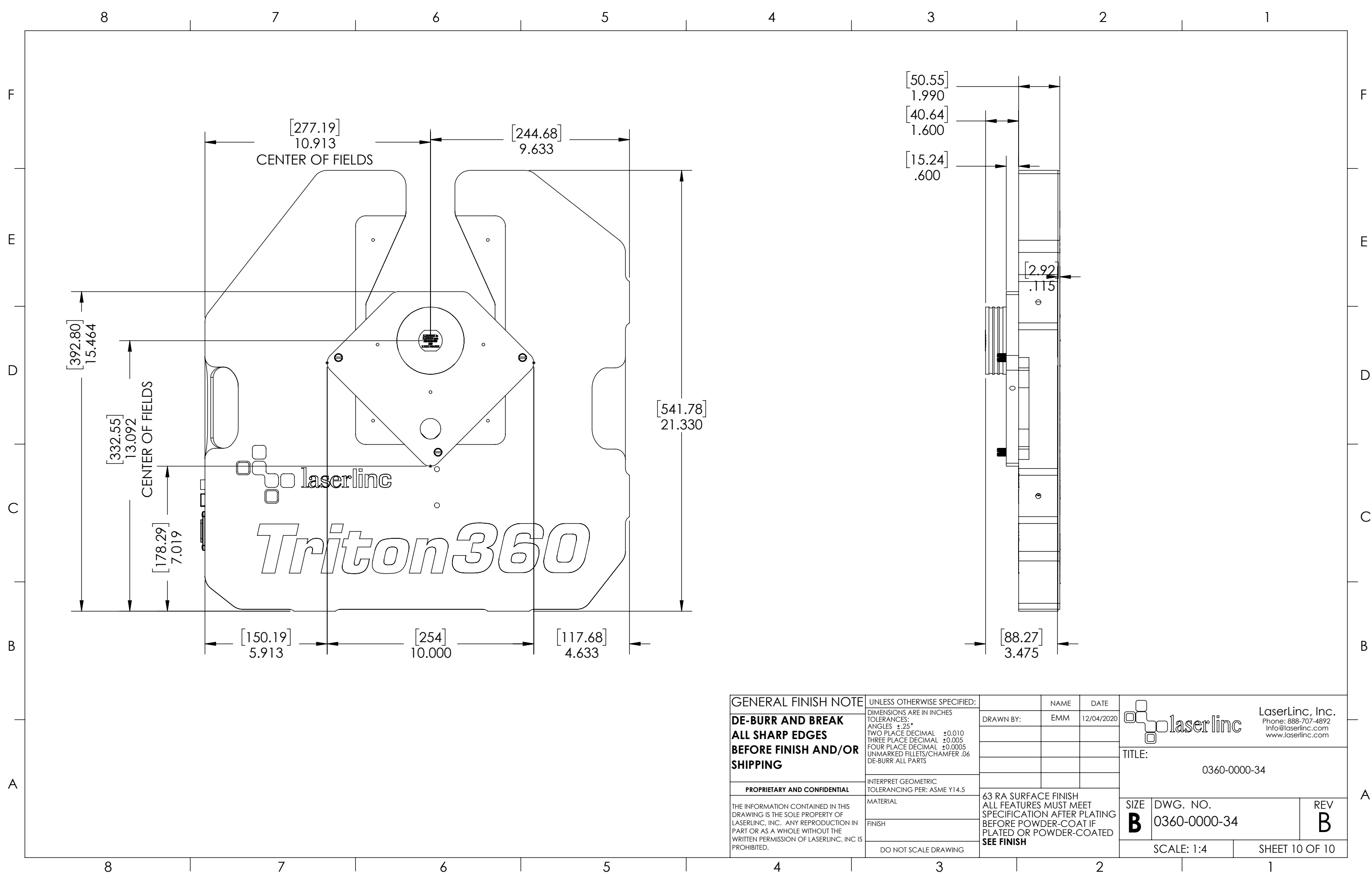

GENERAL FINISH NOTE		UNLESS OTHERWISE SPECIFIED:		NAME	DATE
DE-BURR AND BREAK ALL SHARP EDGES BEFORE FINISH AND/OR SHIPPING		DIMENSIONS ARE IN INCHES TOLERANCES: ANGLES ±.25° TWO PLACE DECIMAL ±0.010 THREE PLACE DECIMAL ±0.005 FOUR PLACE DECIMAL ±0.0005 UNMARKED FILLETS/CHAMFER .06 DE-BURR ALL PARTS		DRAWN BY:	EMM 12/04/2020
PROPRIETARY AND CONFIDENTIAL		INTERPRET GEOMETRIC TOLERANCING PER: ASME Y14.5			
THE INFORMATION CONTAINED IN THIS DRAWING IS THE SOLE PROPERTY OF LASERLINC, INC. ANY REPRODUCTION IN PART OR AS A WHOLE WITHOUT THE WRITTEN PERMISSION OF LASERLINC, INC. IS PROHIBITED.		MATERIAL		63 RA SURFACE FINISH ALL FEATURES MUST MEET SPECIFICATION AFTER PLATING BEFORE POWDER-COAT IF PLATED OR POWDER-COATED SEE FINISH	
		FINISH		TITLE: 0360-0000-34	
		DO NOT SCALE DRAWING		SIZE B	DWG. NO. 0360-0000-34
				SCALE: 1:4	REV B
				SHEET 10 OF 10	

LaserLinc, Inc.
 Phone: 888-707-4892
 info@laserlinc.com
 www.laserlinc.com