

8

7

6

5

4

3

2

1

F

E

D

C

B

A

F

E

D

C

B

A

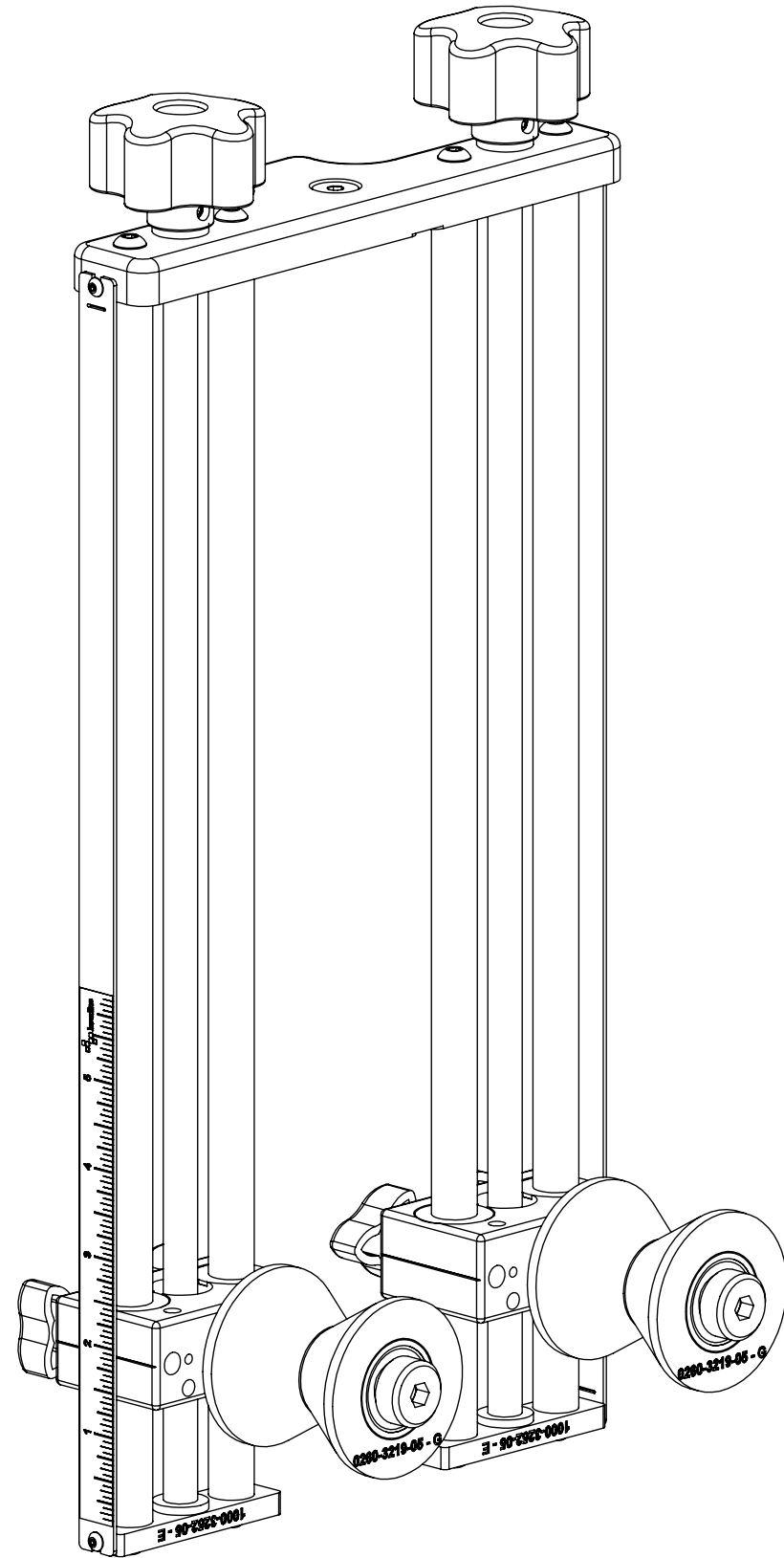

REVISIONS				
ZONE	REV.	DESCRIPTION	DATE	APPROVED
	A	CHECK-IN	3/4/2013	MAM

X60 BODY MOUNT ROLLER GUIDE, 14IN OVERALLS

INDEX

- (1) COVER PAGE
- (2) FIXTURE DIMENSIONS
- (3) MOUNTED DIMENSIONS

GENERAL FINISH NOTE		UNLESS OTHERWISE SPECIFIED:		NAME	DATE	 LaserLinc, Inc. Phone: 888-707-4892 Info@laserlinc.com www.laserlinc.com
DE-BURR AND BREAK ALL SHARP EDGES BEFORE FINISH AND/OR SHIPPING		DIMENSIONS ARE IN INCHES TOLERANCES: ANGLES ±.25° TWO PLACE DECIMAL ±0.010 THREE PLACE DECIMAL ±0.005 FOUR PLACE DECIMAL ±0.0005 UNMARKED FILLETS/CHAMFER .06 DE-BURR ALL PARTS		DRAWN BY:	MWD	
PROPRIETARY AND CONFIDENTIAL		INTERPRET GEOMETRIC TOLERANCING PER: ASME Y14.5				TITLE:
THE INFORMATION CONTAINED IN THIS DRAWING IS THE SOLE PROPERTY OF LASERLINC, INC. ANY REPRODUCTION IN PART OR AS A WHOLE WITHOUT THE WRITTEN PERMISSION OF LASERLINC, INC. IS PROHIBITED.		MATERIAL		63 RA SURFACE FINISH ALL FEATURES MUST MEET SPECIFICATION AFTER PLATING BEFORE POWDER-COAT IF PLATED OR POWDER-COATED SEE FINISH		1000-0003-61 X60 Body Mount Roller Guide, 14in Overalls
		FINISH		DO NOT SCALE DRAWING		SIZE B DWG. NO. 1000-0003-61 REV A
						SCALE: 1:2 SHEET 1 OF 3

8

7

6

5

4

3

2

1

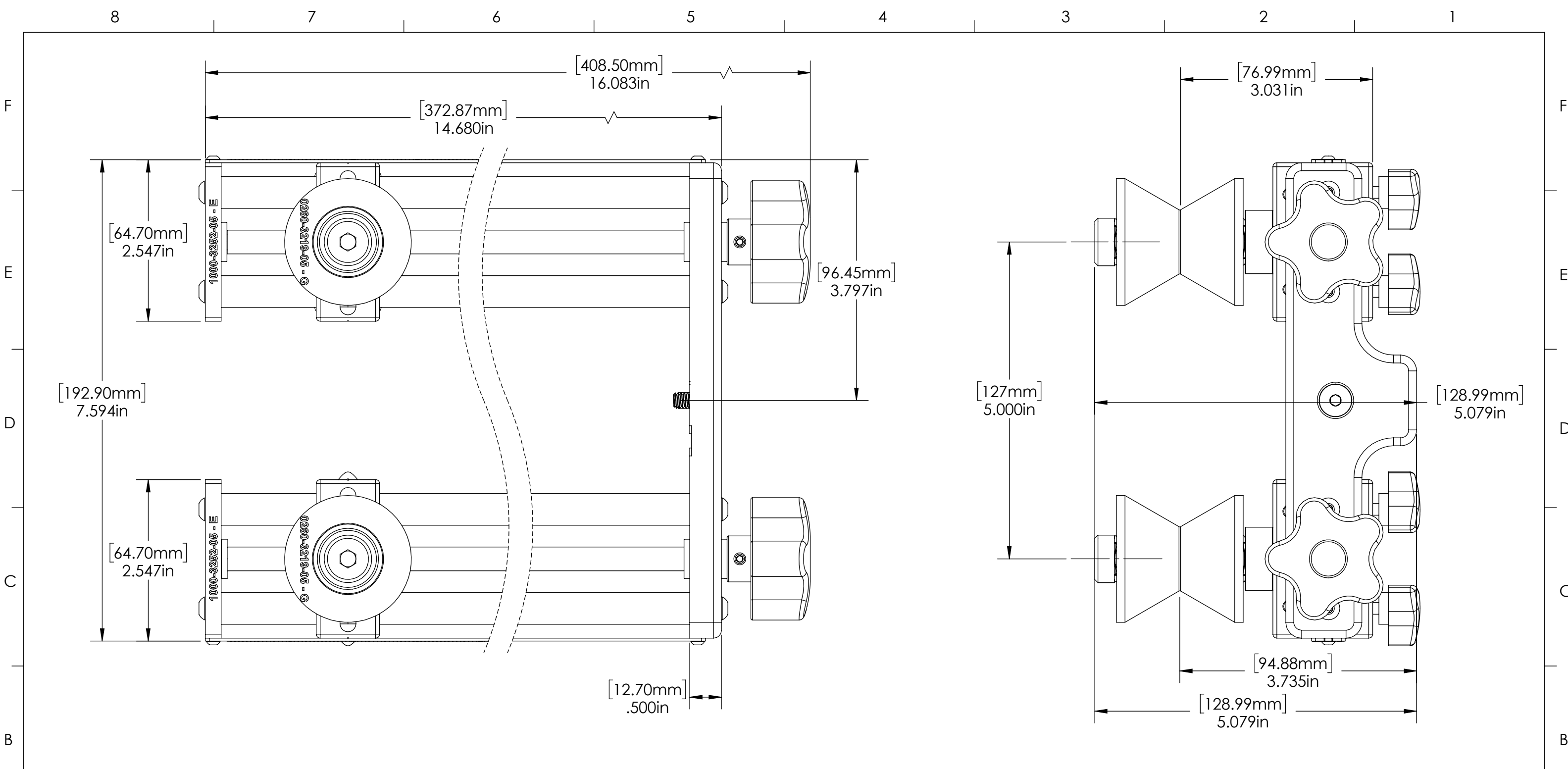

GENERAL FINISH NOTE		UNLESS OTHERWISE SPECIFIED:		NAME	DATE
DE-BURR AND BREAK ALL SHARP EDGES BEFORE FINISH AND/OR SHIPPING		DIMENSIONS ARE IN INCHES TOLERANCES: ANGLES ±.25 TWO PLACE DECIMAL ±0.010 THREE PLACE DECIMAL ±0.005 FOUR PLACE DECIMAL ±0.0005 UNMARKED FILLETS/CHAMFER .06 DE-BURR ALL PARTS		DRAWN BY:	MWD 8/31/2021
PROPRIETARY AND CONFIDENTIAL		INTERPRET GEOMETRIC TOLERANCING PER: ASME Y14.5			
THE INFORMATION CONTAINED IN THIS DRAWING IS THE SOLE PROPERTY OF LASERLINC, INC. ANY REPRODUCTION IN PART OR AS A WHOLE WITHOUT THE WRITTEN PERMISSION OF LASERLINC, INC IS PROHIBITED.		MATERIAL		63 RA SURFACE FINISH ALL FEATURES MUST MEET SPECIFICATION AFTER PLATING BEFORE POWDER-COAT IF PLATED OR POWDER-COATED SEE FINISH	
		FINISH			
		DO NOT SCALE DRAWING			
				 LaserLinc, Inc. Phone: 888-707-4892 info@laserlinc.com www.laserlinc.com	
				TITLE: 1000-0003-61 X60 Body Mount Roller Guide, 14in Overalls	
SIZE	DWG. NO.			REV	
B	1000-0003-61			A	
SCALE: 2:3			SHEET 2 OF 3		

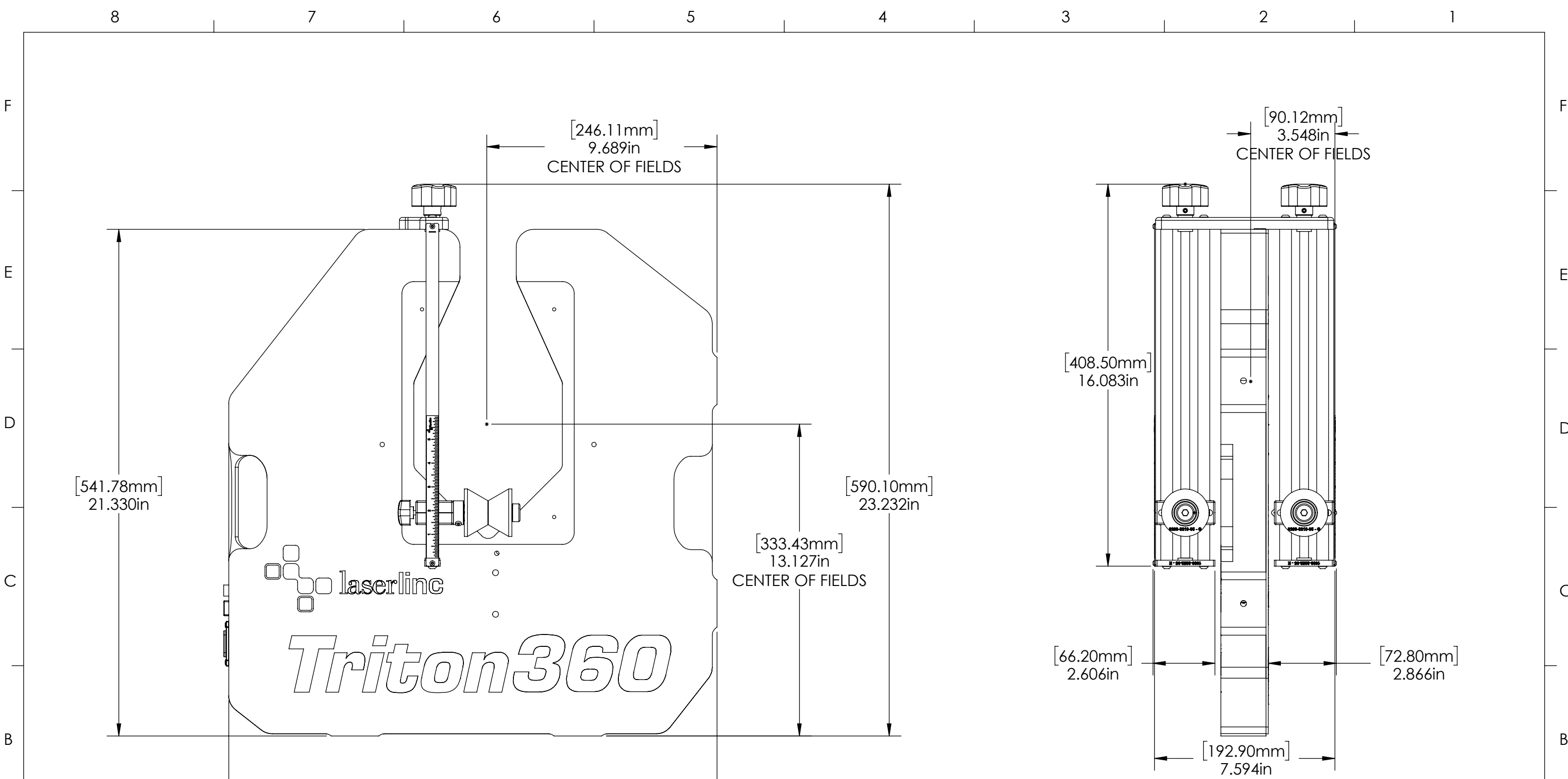

GENERAL FINISH NOTE		UNLESS OTHERWISE SPECIFIED:		NAME	DATE
DE-BURR AND BREAK ALL SHARP EDGES BEFORE FINISH AND/OR SHIPPING		DIMENSIONS ARE IN INCHES TOLERANCES: ANGLES ±.25° TWO PLACE DECIMAL ±0.010 THREE PLACE DECIMAL ±0.005 FOUR PLACE DECIMAL ±0.0005 UNMARKED FILLETS/CHAMFER .06 DE-BURR ALL PARTS		DRAWN BY:	MWD 8/31/2021
PROPRIETARY AND CONFIDENTIAL		INTERPRET GEOMETRIC TOLERANCING PER: ASME Y14.5			
THE INFORMATION CONTAINED IN THIS DRAWING IS THE SOLE PROPERTY OF LASERLINC, INC. ANY REPRODUCTION IN PART OR AS A WHOLE WITHOUT THE WRITTEN PERMISSION OF LASERLINC, INC. IS PROHIBITED.		MATERIAL		63 RA SURFACE FINISH ALL FEATURES MUST MEET SPECIFICATION AFTER PLATING BEFORE POWDER-COAT IF PLATED OR POWDER-COATED SEE FINISH	
		FINISH		TITLE: 1000-0003-61 X60 Body Mount Roller Guide, 14in Overalls	
		DO NOT SCALE DRAWING		SIZE B	DWG. NO. 1000-0003-61
				REV A	
				SCALE: 1:4	SHEET 3 OF 3

LaserLinc, Inc.
 Phone: 888-707-4892
 Info@laserlinc.com
 www.laserlinc.com