

REVISIONS

ZONE	REV.	DESCRIPTION	DATE	APPROVED
	A	CHECK-IN	4/13/2017	MAM
	B	LOWER PORTION OF STAND IS NOW SUB-ASSEMBLY	3/23/2023	CJM

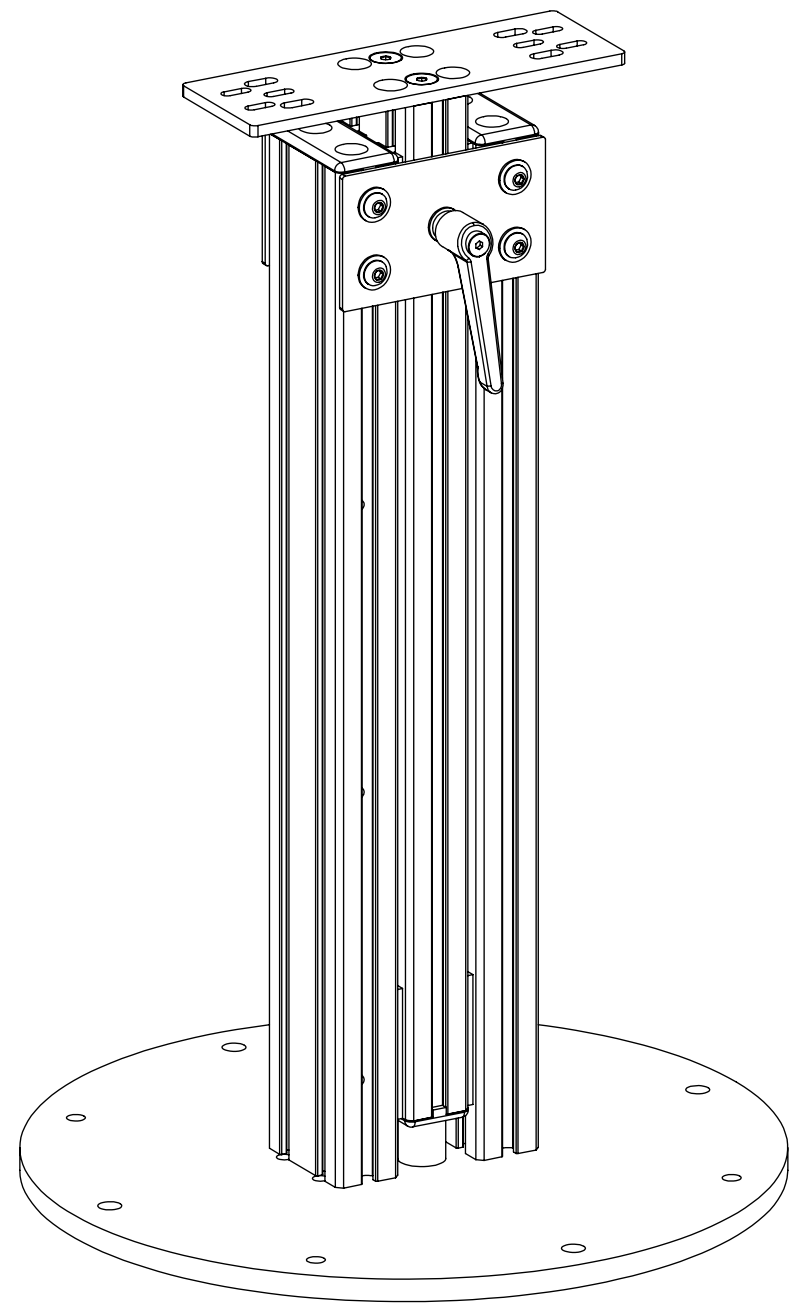

IMPACT RESISTANT STAND SPLIT-HEAD MICROMETER

INDEX

- (1) COVER PAGE
- (2) BOM TABLE
- (3) MOUNT BASE & TOP
- (4) FIXTURE OVERALLS

GENERAL FINISH NOTE		UNLESS OTHERWISE SPECIFIED:		NAME	DATE
DE-BURR AND BREAK ALL SHARP EDGES BEFORE FINISH AND/OR SHIPPING		DIMENSIONS ARE IN INCHES TOLERANCES: ANGLES ±.25° TWO PLACE DECIMAL ±0.010 THREE PLACE DECIMAL ±0.005 FOUR PLACE DECIMAL ±0.0005 UNMARKED FILLETS/CHAMFER .06 DE-BURR ALL PARTS		DRAWN BY:	EMM 11/30/2020
PROPRIETARY AND CONFIDENTIAL		INTERPRET GEOMETRIC TOLERANCING PER: ASME Y14.5			
THE INFORMATION CONTAINED IN THIS DRAWING IS THE SOLE PROPERTY OF LASERLINC, INC. ANY REPRODUCTION IN PART OR AS A WHOLE WITHOUT THE WRITTEN PERMISSION OF LASERLINC, INC. IS PROHIBITED.		MATERIAL		63 RA SURFACE FINISH ALL FEATURES MUST MEET SPECIFICATION AFTER PLATING BEFORE POWDER-COAT IF PLATED OR POWDER-COATED SEE FINISH	
		FINISH			
		DO NOT SCALE DRAWING			
 LASERLINC, INC. PHONE: 888-707-4892 INFO@LASERLINC.COM WWW.LASERLINC.COM				TITLE: IMPACT RESISTANT STAND, SPLIT-HEAD MICROMETER	
SIZE B	DWG. NO. 0200-0004-28		REV B		
SCALE: 1:4			SHEET 1 OF 4		

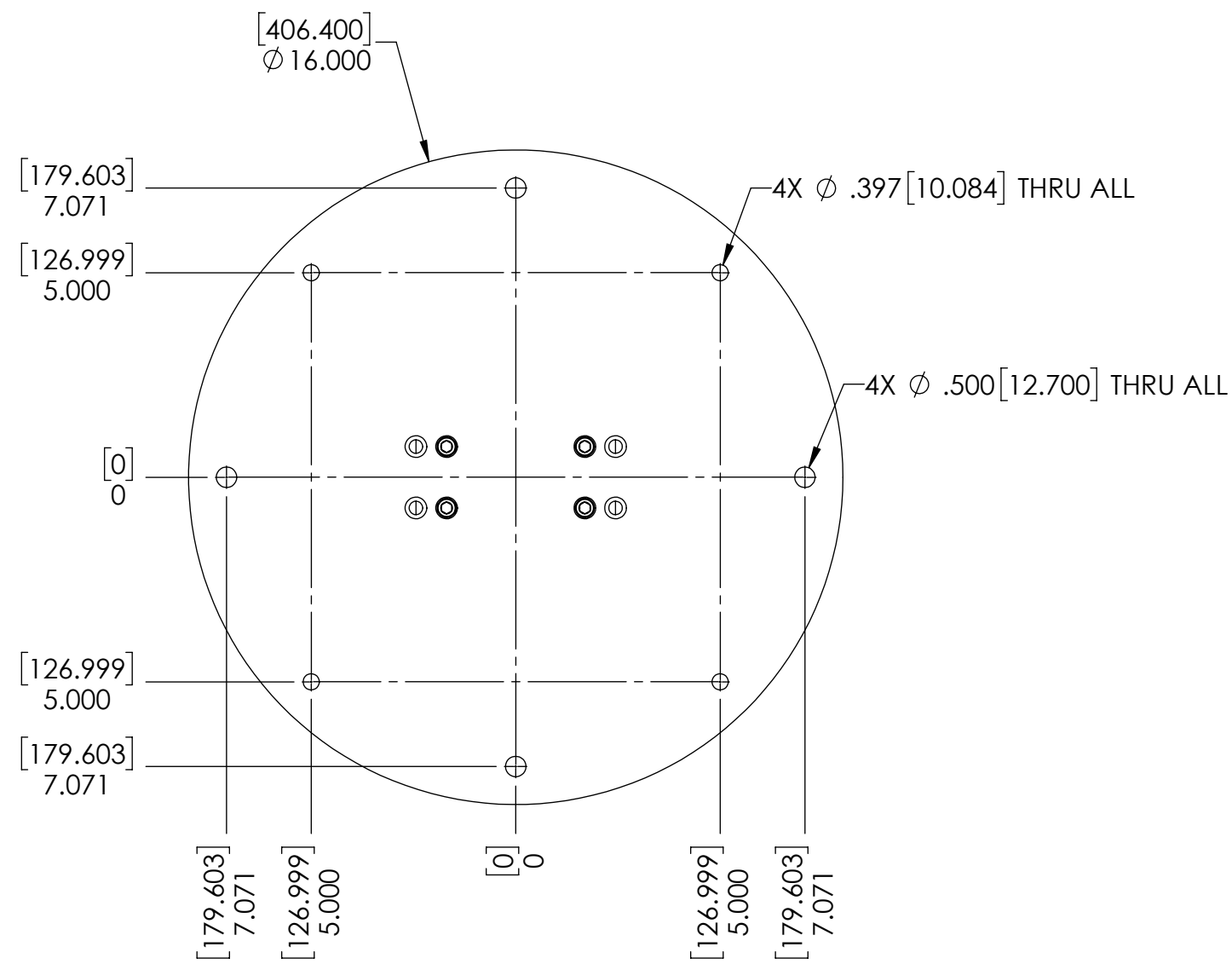
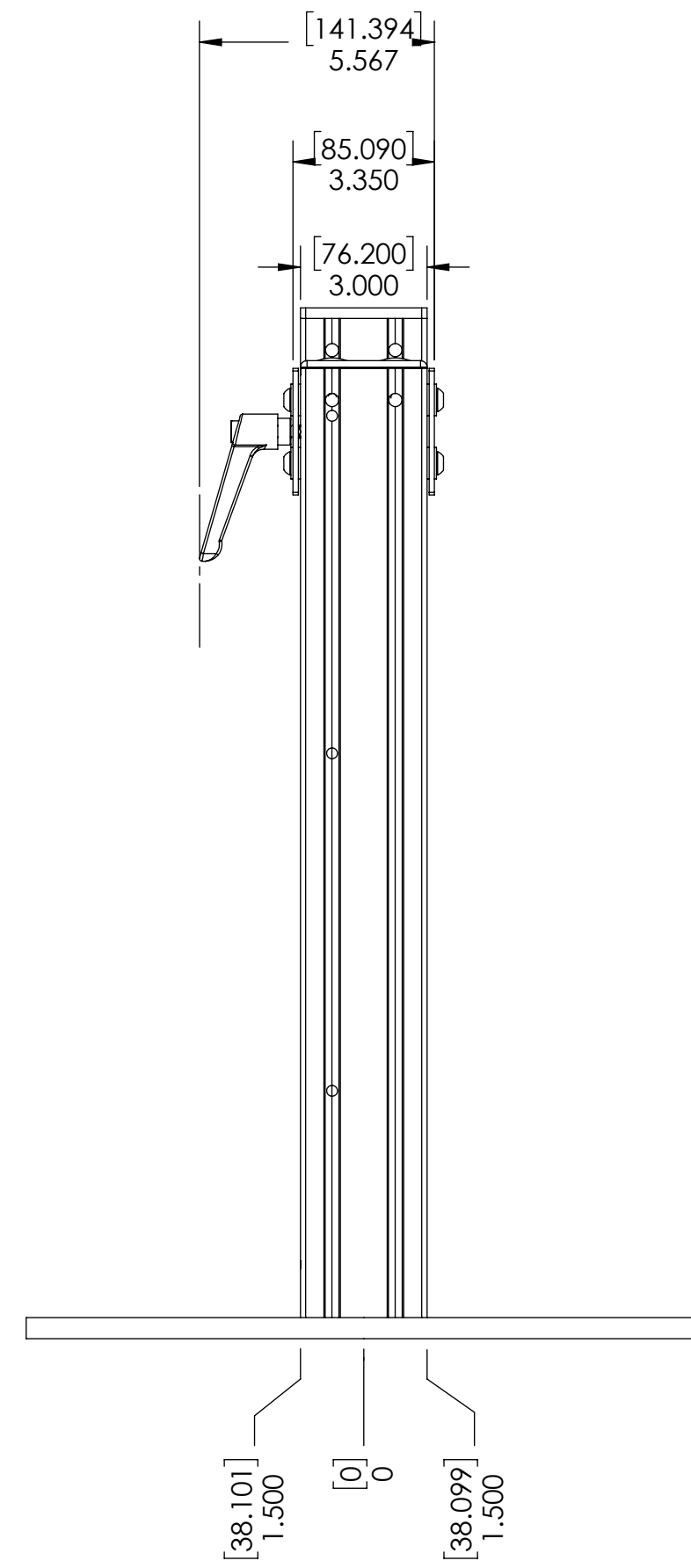
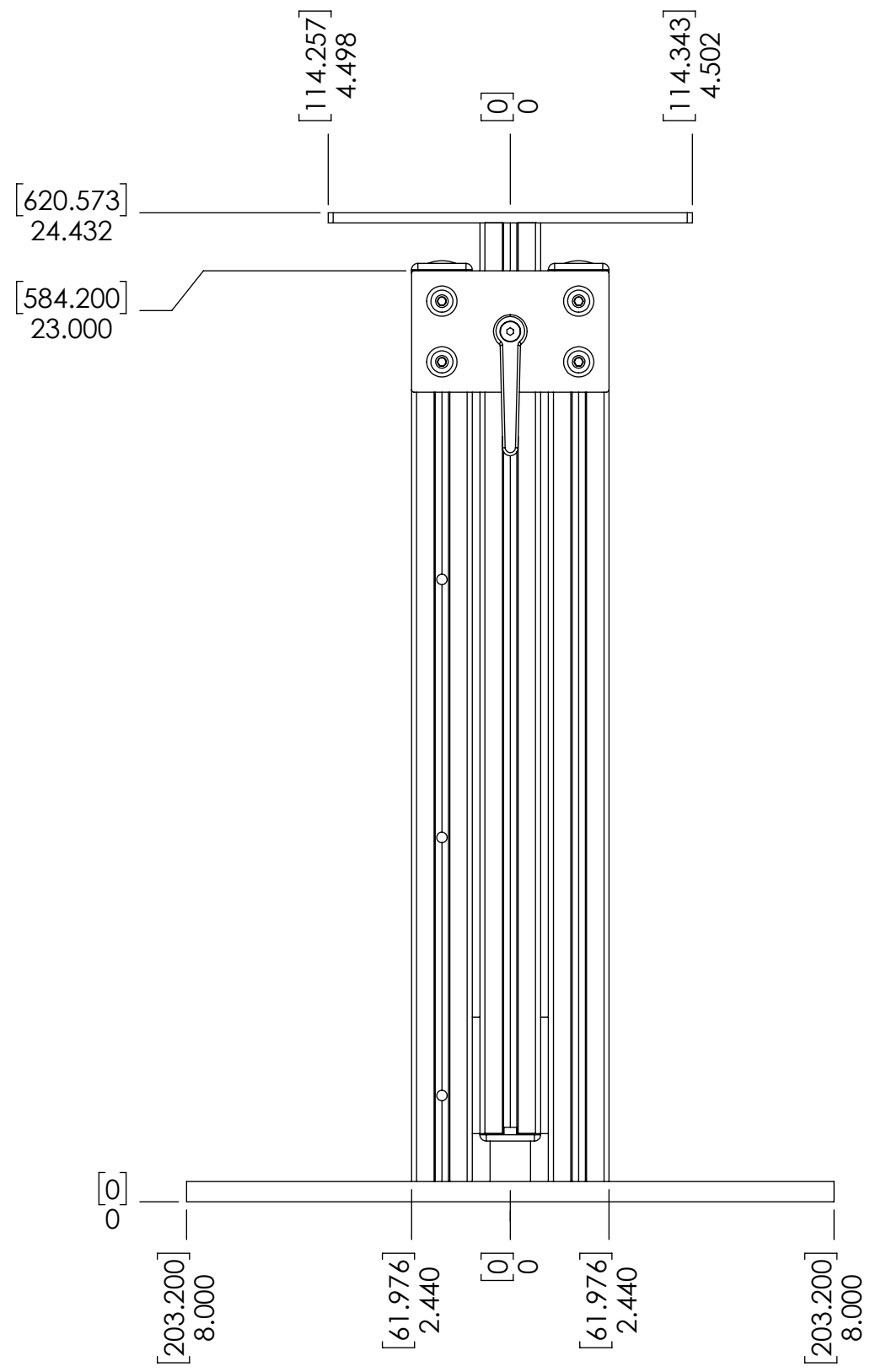

GENERAL FINISH NOTE		UNLESS OTHERWISE SPECIFIED:		NAME	DATE
DE-BURR AND BREAK ALL SHARP EDGES BEFORE FINISH AND/OR SHIPPING		DIMENSIONS ARE IN INCHES		DRAWN BY:	EMM
PROPRIETARY AND CONFIDENTIAL		TOLERANCES:			11/30/2020
THE INFORMATION CONTAINED IN THIS DRAWING IS THE SOLE PROPERTY OF LASERLINC, INC. ANY REPRODUCTION IN PART OR AS A WHOLE WITHOUT THE WRITTEN PERMISSION OF LASERLINC, INC IS PROHIBITED.		ANGLES: ±25°			
		TWO PLACE DECIMAL ±0.010			
		THREE PLACE DECIMAL ±0.005			
		FOUR PLACE DECIMAL ±0.0005			
		UNMARKED FILLETS/CHAMFER .06			
		DE-BURR ALL PARTS			
		INTERPRET GEOMETRIC TOLERANCING PER: ASME Y14.5			
		MATERIAL			
		FINISH			
		DO NOT SCALE DRAWING			
		63 RA SURFACE FINISH ALL FEATURES MUST MEET SPECIFICATION AFTER PLATING BEFORE POWDER-COAT IF PLATED OR POWDER-COATED			
		SEE FINISH			
		TITLE:		IMPACT RESISTANT STAND, SPLIT-HEAD MICROMETER	
SIZE	DWG. NO.	REV			
C	0200-0004-28	B			
SCALE: 1:4		SHEET 4 OF 4			

