

8

7

6

5

4

3

2

1

F

E

D

C

B

A

F

E

D

C

B

A

REVISIONS				
ZONE	REV.	DESCRIPTION	DATE	APPROVED
	A	CHECK IN	02/19/2020	JWB
	B	REMOVED FLAT, ADDED DETENT GROOVE, INCREASED LENGTH, REDIMENSIONED	8/12/2020	JWB
	C	WAS .249/.248	9/24/2020	JWB
	D	MATL WAS A2, DELETED HT TR & FINISH	10/1/2020	JWB

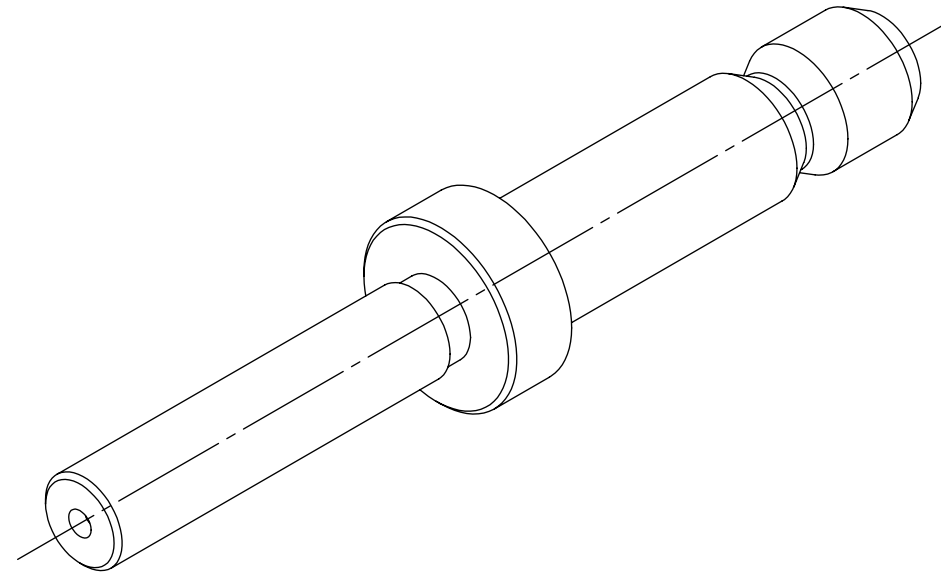

ID-OD BENCHLINC SUPPORT PIN

INDEX

- (1) COVER PAGE
- (2) DIMENSIONS

GENERAL FINISH NOTE		UNLESS OTHERWISE SPECIFIED:		NAME	DATE	 LaserLinc, Inc. Phone: 888-707-4892 Info@laserlinc.com www.laserlinc.com
DE-BURR AND BREAK ALL SHARP EDGES BEFORE FINISH AND/OR SHIPPING		DIMENSIONS ARE IN INCHES TOLERANCES: ANGLES ±.25° TWO PLACE DECIMAL ±0.010 THREE PLACE DECIMAL ±0.005 FOUR PLACE DECIMAL ±0.0005 UNMARKED FILLETS/CHAMFER .06 DE-BURR ALL PARTS		DRAWN BY:	JWB	
PROPRIETARY AND CONFIDENTIAL THE INFORMATION CONTAINED IN THIS DRAWING IS THE SOLE PROPERTY OF LASERLINC, INC. ANY REPRODUCTION IN PART OR AS A WHOLE WITHOUT THE WRITTEN PERMISSION OF LASERLINC, INC. IS PROHIBITED.		INTERPRET GEOMETRIC TOLERANCING PER: ASME Y14.5				TITLE:
		MATERIAL 304 STAINLESS STEEL				63 RA SURFACE FINISH ALL FEATURES MUST MEET SPECIFICATION AFTER PLATING BEFORE POWDER-COAT IF PLATED OR POWDER-COATED SEE FINISH
		FINISH NONE				SIZE B DWG. NO. 6500-3238-05 REV D
		DO NOT SCALE DRAWING				SCALE: 3:1 SHEET 1 OF 2

8

7

6

5

4

3

2

1

	8	7	6	5	4	3	2	1	
	PART NUMBER			A	B				
	6500-3238-05-.093 ID-OD BenchLinc Support Pin			.093	.38				
	6500-3238-05-.125 ID-OD BenchLinc Support Pin			.125	.38				
F	6500-3238-05-.188 ID-OD BenchLinc Support Pin			.188	.38				
	6500-3238-05-.250 ID-OD BenchLinc Support Pin			.250	.38				
	6500-3238-05-.375 ID-OD BenchLinc Support Pin			.375	.50				
	6500-3238-05-.500 ID-OD BenchLinc Support Pin			.500	.75				
	6500-3238-05-.625 ID-OD BenchLinc Support Pin			.625	.88				
	6500-3238-05-.750 ID-OD BenchLinc Support Pin			.750	1.00				

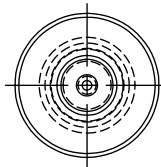
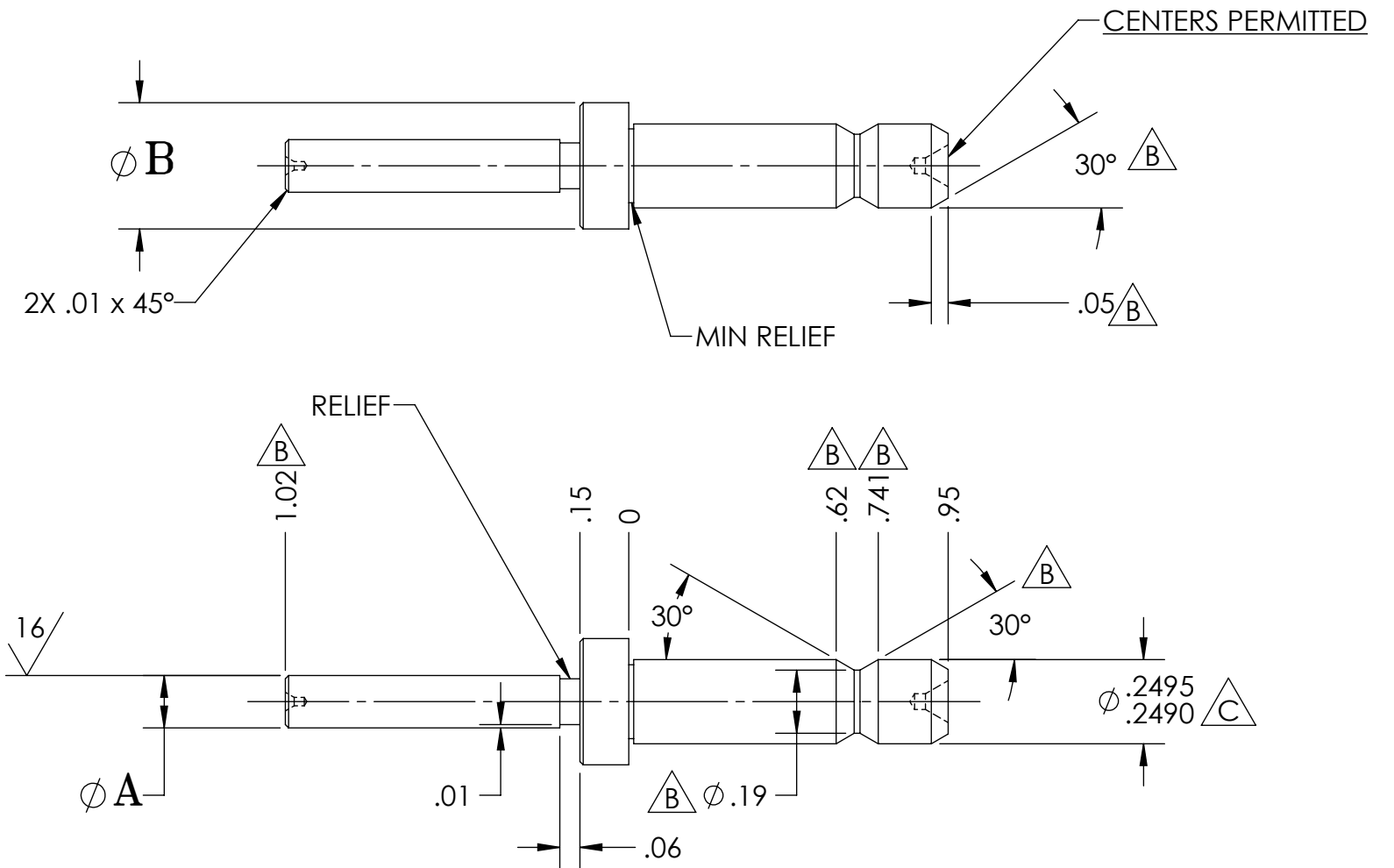

GENERAL FINISH NOTE DE-BURR AND BREAK ALL SHARP EDGES BEFORE FINISH AND/OR SHIPPING	UNLESS OTHERWISE SPECIFIED: DIMENSIONS ARE IN INCHES TOLERANCES: ANGLES $\pm .25$ TWO PLACE DECIMAL ± 0.010 THREE PLACE DECIMAL ± 0.005 FOUR PLACE DECIMAL ± 0.0005 UNMARKED FILLETS/CHAMFER .06 DE-BURR ALL PARTS	NAME DATE DRAWN BY: JWB 02/13/2020	LaserLinc, Inc. Phone: 888-707-4892 Info@laserlinc.com www.laserlinc.com
	PROPRIETARY AND CONFIDENTIAL THE INFORMATION CONTAINED IN THIS DRAWING IS THE SOLE PROPERTY OF LASERLINC, INC. ANY REPRODUCTION IN PART OR AS A WHOLE WITHOUT THE WRITTEN PERMISSION OF LASERLINC, INC. IS PROHIBITED.	INTERPRET GEOMETRIC TOLERANCING PER: ASME Y14.5 MATERIAL 304 STAINLESS STEEL FINISH NONE DO NOT SCALE DRAWING	
	63 RA SURFACE FINISH ALL FEATURES MUST MEET SPECIFICATION AFTER PLATING BEFORE POWDER-COAT IF PLATED OR POWDER-COATED SEE FINISH	SIZE B DWG. NO. 6500-3238-05 REV D	SCALE: 2:1 SHEET 2 OF 2