

REVISIONS				
ZONE	REV.	DESCRIPTION	DATE	APPROVED
	A	CHECK-IN	8/26/2021	EMM
	B	CHANGED MOUNTING HARDWARE	12/8/2022	EMM
	C	LOWER PORTION OF STAND IS NOW SUB-ASSEMBLY	3/27/2023	CJM

IMPACT RESISTANT MOBILE STAND, MIRROR MICROMETER

INDEX

- (1) COVER PAGE
- (2) BOM TABLE
- (3) MICROMETER MOUNTING PLATE
- (4) MOUNT 230 MICROMETER
- (5) MOUNT 260 MICROMETER
- (6) MOUNT 331 MICROMETER
- (7) MOUNT 360 MICROMETER
- (8) MOUNT 2120 MICROMETER
- (9) FIXTURE OVERALLS
- (10) MOUNT 230 OVERALLS
- (11) MOUNT 260 OVERALLS
- (12) MOUNT 331 OVERALLS
- (13) MOUNT 360 OVERALLS
- (14) MOUNT 2120 OVERALLS

GENERAL FINISH NOTE		UNLESS OTHERWISE SPECIFIED:		NAME	DATE
DE-BURR AND BREAK ALL SHARP EDGES BEFORE FINISH AND/OR SHIPPING		DIMENSIONS ARE IN INCHES TOLERANCES: ANGLES ±.25° TWO PLACE DECIMAL ±0.010 THREE PLACE DECIMAL ±0.005 FOUR PLACE DECIMAL ±0.0005 UNMARKED FILLETS/CHAMFER .06 DE-BURR ALL PARTS		DRAWN BY:	EMM 08/26/2021
PROPRIETARY AND CONFIDENTIAL		INTERPRET GEOMETRIC TOLERANCING PER: ASME Y14.5			
THE INFORMATION CONTAINED IN THIS DRAWING IS THE SOLE PROPERTY OF LASERLINC, INC. ANY REPRODUCTION IN PART OR AS A WHOLE WITHOUT THE WRITTEN PERMISSION OF LASERLINC, INC. IS PROHIBITED.		MATERIAL		63 RA SURFACE FINISH ALL FEATURES MUST MEET SPECIFICATION AFTER PLATING BEFORE POWDER-COAT IF PLATED OR POWDER-COATED SEE FINISH	
		FINISH		TITLE: IMPACT RESISTANT MOBILE STAND, MIRROR MICROMETER	
		DO NOT SCALE DRAWING		SIZE B	DWG. NO. 0200-0006-28
				REV C	
				SCALE: 1:5	SHEET 1 OF 14

LASERLINC, INC.
 PHONE: 888-707-4892
 INFO@LASERLINC.COM
 WWW.LASERLINC.COM

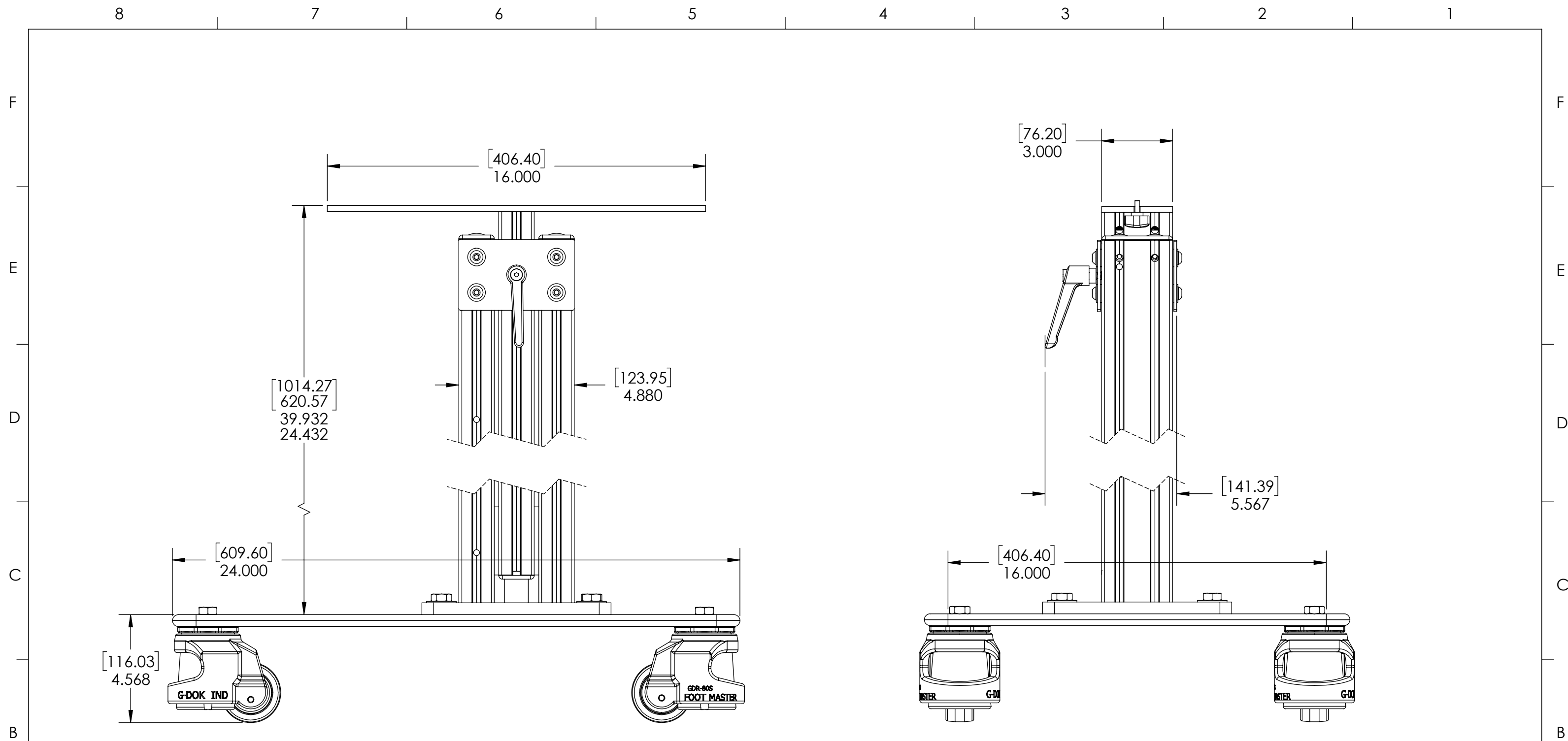

GENERAL FINISH NOTE DE-BURR AND BREAK ALL SHARP EDGES BEFORE FINISH AND/OR SHIPPING	UNLESS OTHERWISE SPECIFIED: DIMENSIONS ARE IN INCHES TOLERANCES: ANGLES ±.25° TWO PLACE DECIMAL ±0.010 THREE PLACE DECIMAL ±0.005 FOUR PLACE DECIMAL ±0.0005 UNMARKED FILLETS/CHAMFER .06 DE-BURR ALL PARTS	NAME EMM	DATE 08/26/2021	 LASERLINC, INC. PHONE: 888-707-4892 INFO@LASERLINC.COM WWW.LASERLINC.COM	
	PROPRIETARY AND CONFIDENTIAL THE INFORMATION CONTAINED IN THIS DRAWING IS THE SOLE PROPERTY OF LASERLINC, INC. ANY REPRODUCTION IN PART OR AS A WHOLE WITHOUT THE WRITTEN PERMISSION OF LASERLINC, INC. IS PROHIBITED.	INTERPRET GEOMETRIC TOLERANCING PER: ASME Y14.5 MATERIAL FINISH DO NOT SCALE DRAWING	DRAWN BY: 		TITLE: IMPACT RESISTANT MOBILE STAND, MIRROR MICROMETER
		63 RA SURFACE FINISH ALL FEATURES MUST MEET SPECIFICATION AFTER PLATING BEFORE POWDER-COAT IF PLATED OR POWDER-COATED SEE FINISH		SIZE B DWG. NO. 0200-0006-28 SCALE: 1:4	REV C SHEET 9 OF 14

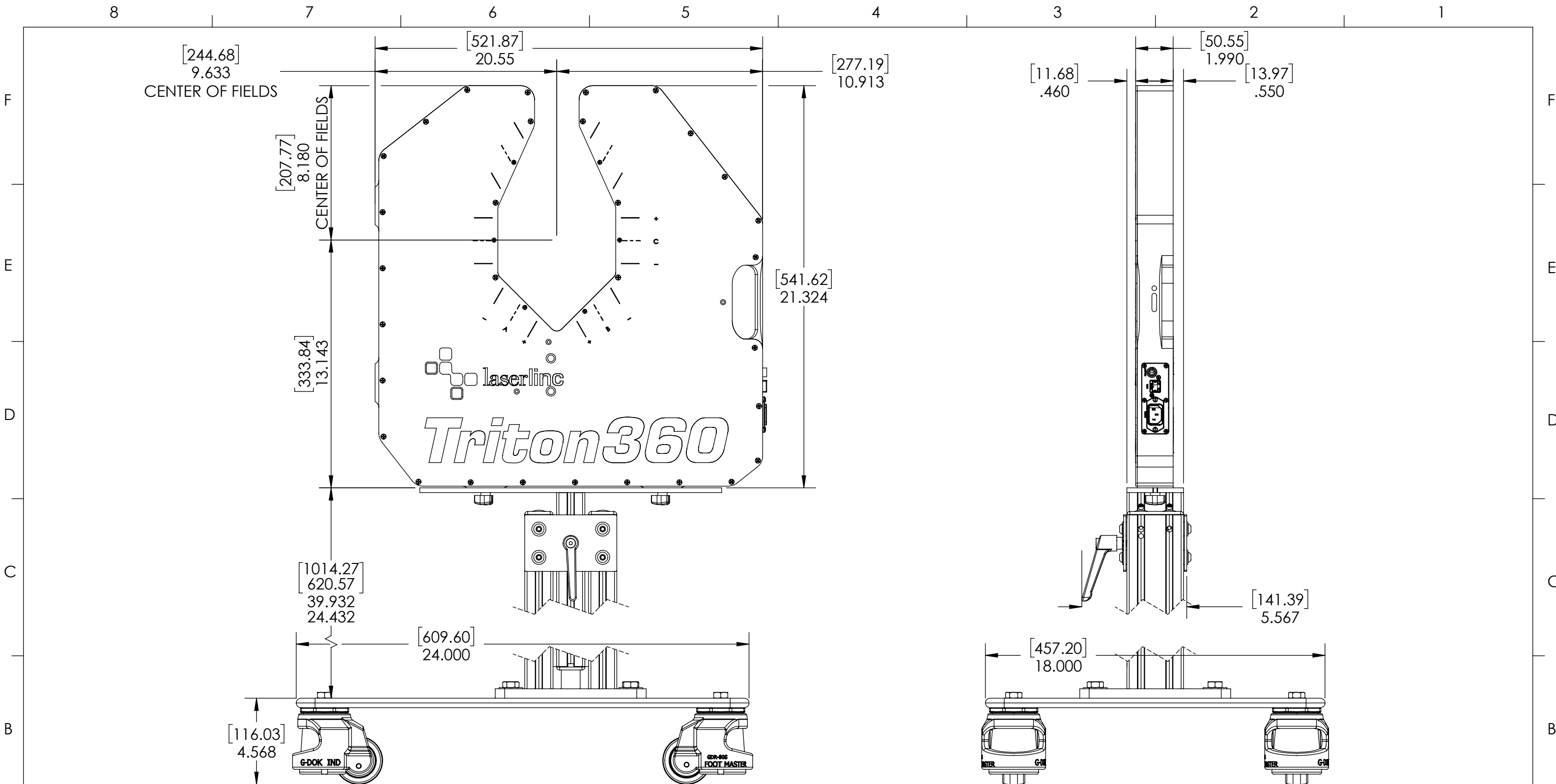

GENERAL FINISH NOTE DE-BURR AND BREAK ALL SHARP EDGES BEFORE FINISH AND/OR SHIPPING	UNLESS OTHERWISE SPECIFIED: DIMENSIONS ARE IN INCHES TOLERANCES: ANGLES ±.25 TWO PLACE DECIMAL ±0.010 THREE PLACE DECIMAL ±0.005 FOUR PLACE DECIMAL ±0.0005 UNMARKED FILLETS/CHAMFER .06 DE-BURR ALL PARTS	NAME DATE	laserline LASERLINC, INC. PHONE: 888-707-4892 INFO@LASERLINC.COM WWW.LASERLINC.COM		
	PROPRIETARY AND CONFIDENTIAL THE INFORMATION CONTAINED IN THIS DRAWING IS THE SOLE PROPERTY OF LASERLINC, INC. ANY REPRODUCTION IN PART OR AS A WHOLE WITHOUT THE WRITTEN PERMISSION OF LASERLINC, INC. IS PROHIBITED.	INTERPRET GEOMETRIC TOLERANCING PER: ASME Y14.5 MATERIAL FINISH DO NOT SCALE DRAWING	DRAWN BY: EMM 08/26/2021	TITLE: IMPACT RESISTANT MOBILE STAND, MIRROR MICROMETER	
		63 RA SURFACE FINISH ALL FEATURES MUST MEET SPECIFICATION AFTER PLATING BEFORE POWDER-COAT IF PLATED OR POWDER-COATED SEE FINISH		SIZE B DWG. NO. 0200-0006-28 SCALE: 1:5	REV C SHEET 13 OF 14