

8 7 6 5 4 3 2 1

REVISIONS				
ZONE	REV.	DESCRIPTION	DATE	APPROVED
	A	Check-In	11/30/2012	MAM

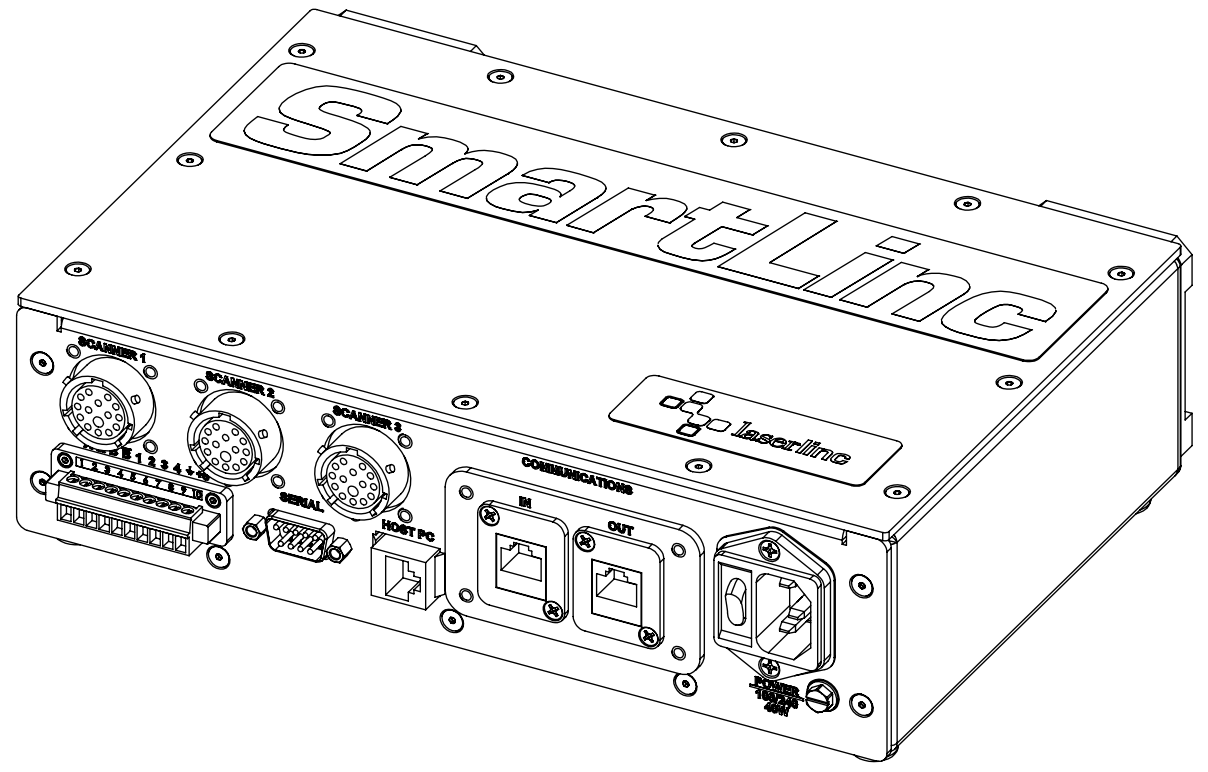

SmartLinc Overall Dimensions

INDEX

- (1) Cover Page
- (2) Dimensions

UNLESS OTHERWISE SPECIFIED:		NAME	DATE
DIMENSIONS ARE IN INCHES		DRAWN BY:	MAM 11/30/2012
TOLERANCES:			
ANGULAR: MACH ± BEND ±			
TWO PLACE DECIMAL ±0.010			
THREE PLACE DECIMAL ±0.005			
FOUR PLACE DECIMAL ±0.0005			
ANGLES ±.25°			
UNMARKED FILLETS/ROUNDS R.0625			
DE-BURR ALL PARTS			
INTERPRET GEOMETRIC TOLERANCING PER:		 LaserLinc, Inc. Phone: 888-707-4892 Info@laserlinc.com www.laserlinc.com	
PROPRIETARY AND CONFIDENTIAL THE INFORMATION CONTAINED IN THIS DRAWING IS THE SOLE PROPERTY OF LASERLINC, INC. ANY REPRODUCTION IN PART OR AS A WHOLE WITHOUT THE WRITTEN PERMISSION OF LASERLINC, INC IS PROHIBITED.		TITLE: 00401-01 SmartLinc Overall Dimensions	
MATERIAL		SIZE	DWG. NO.
FINISH		B	00401-01
DO NOT SCALE DRAWING		REV	A
		SCALE: 1:2 SHEET 1 OF 2	

8 7 6 5 4 3 2 1

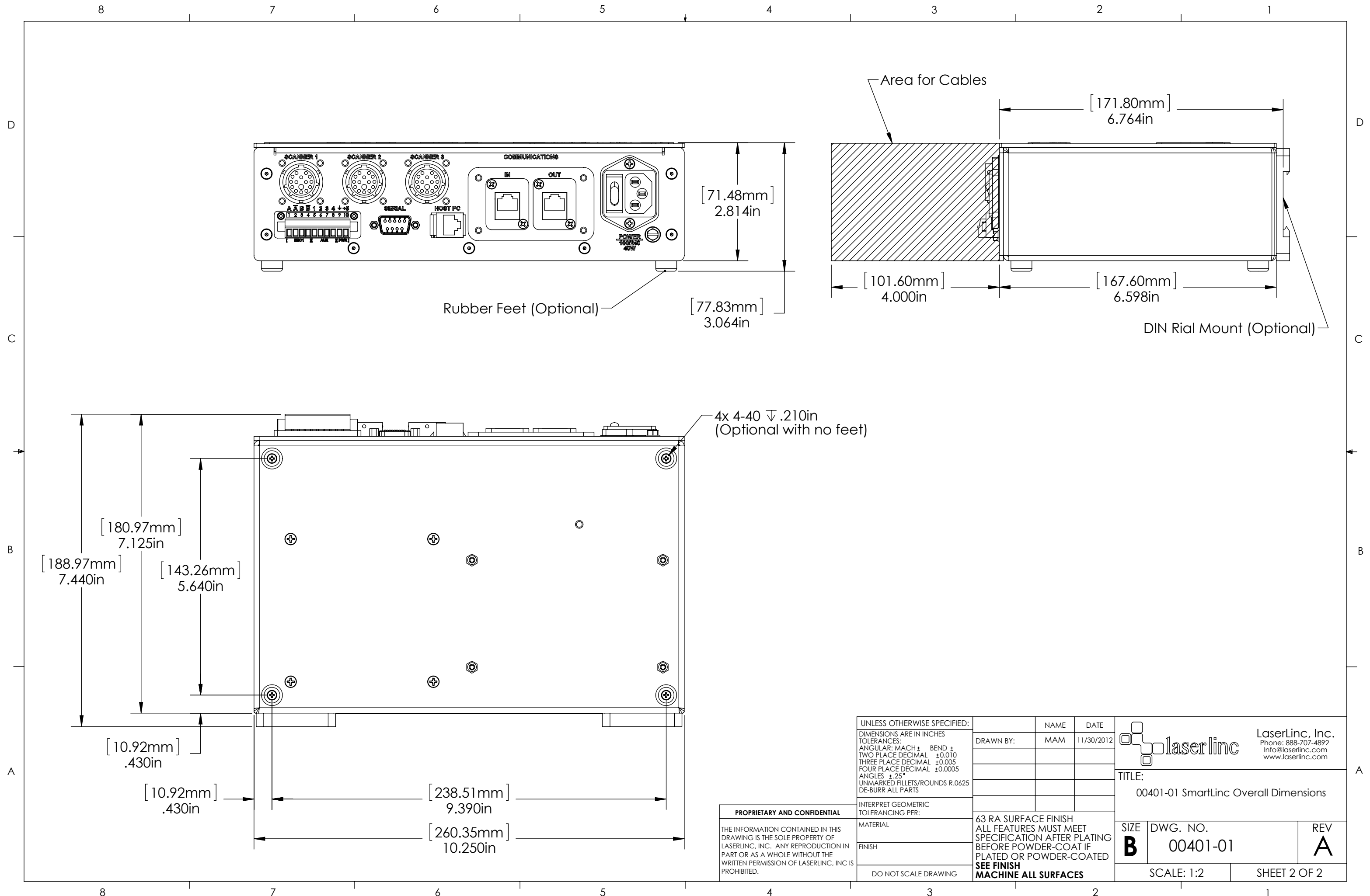

UNLESS OTHERWISE SPECIFIED:		NAME	DATE
DIMENSIONS ARE IN INCHES		DRAWN BY:	MAM 11/30/2012
TOLERANCES:			
ANGULAR: MACH \pm BEND \pm			
TWO PLACE DECIMAL \pm 0.010			
THREE PLACE DECIMAL \pm 0.005			
FOUR PLACE DECIMAL \pm 0.0005			
ANGLES \pm 25°			
UNMARKED FILLETS/ROUNDS R.0625			
DE-BURR ALL PARTS			
INTERPRET GEOMETRIC TOLERANCING PER:		 LaserLinc, Inc. Phone: 888-707-4892 Info@laserlinc.com www.laserlinc.com	
TITLE:		00401-01 SmartLinc Overall Dimensions	
MATERIAL		SIZE	DWG. NO.
FINISH		B	00401-01
DO NOT SCALE DRAWING		REV	A
		SCALE: 1:2 SHEET 2 OF 2	

PROPRIETARY AND CONFIDENTIAL

THE INFORMATION CONTAINED IN THIS DRAWING IS THE SOLE PROPERTY OF LASERLINC, INC. ANY REPRODUCTION IN PART OR AS A WHOLE WITHOUT THE WRITTEN PERMISSION OF LASERLINC, INC IS PROHIBITED.

63 RA SURFACE FINISH
 ALL FEATURES MUST MEET SPECIFICATION AFTER PLATING BEFORE POWDER-COAT IF PLATED OR POWDER-COATED
SEE FINISH MACHINE ALL SURFACES