

REVISIONS

ZONE	REV.	DESCRIPTION	DATE	APPROVED
	A	CHECK-IN	3/19/2020	EMM
	B	CHANGED MOUNTING HARDWARE	11/5/2021	EMM

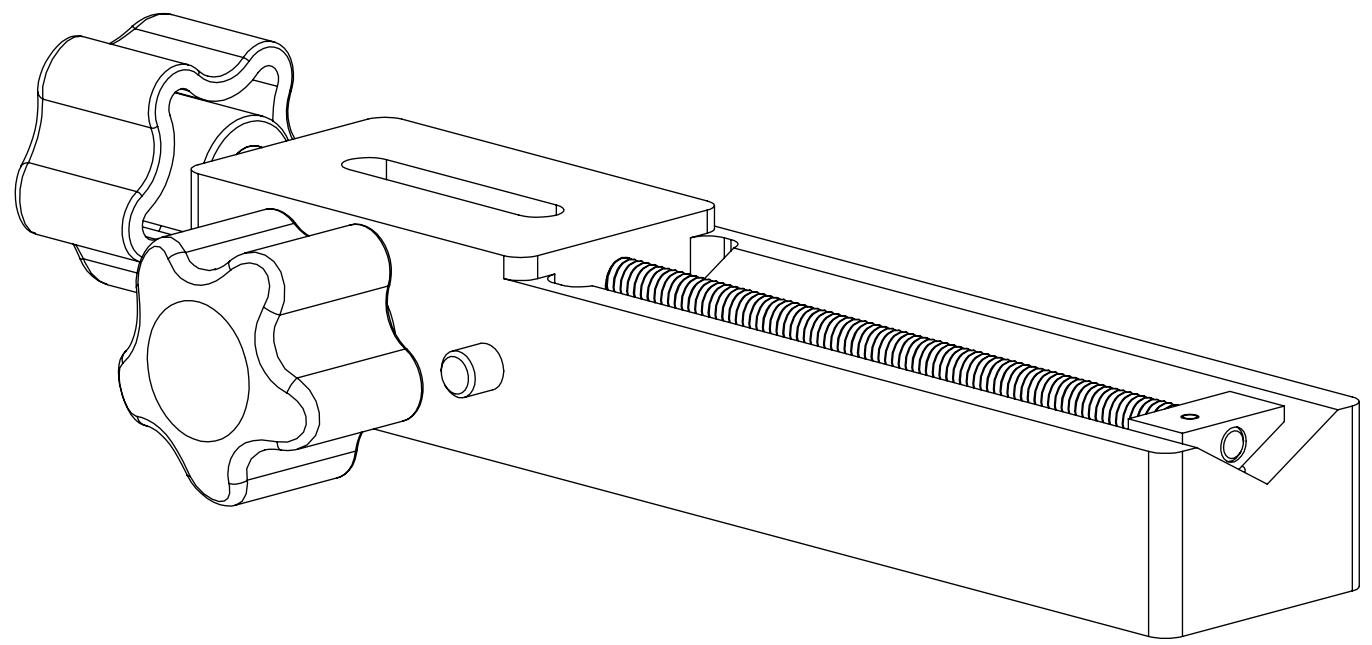

# MAGNET V-BLOCK WITH ADJUSTABLE STOP

## INDEX

- (1) COVER PAGE
- (2) BOM TABLE
- (3) ASSEMBLY
- (4) MOUNT TO HOME PART HOLDER
- (5) OVERALLS

<b>GENERAL FINISH NOTE</b>		UNLESS OTHERWISE SPECIFIED:		NAME	DATE
<b>DE-BURR AND BREAK ALL SHARP EDGES BEFORE FINISH AND/OR SHIPPING</b>		DIMENSIONS ARE IN INCHES TOLERANCES: ANGLES ±.25° TWO PLACE DECIMAL ±0.010 THREE PLACE DECIMAL ±0.005 FOUR PLACE DECIMAL ±0.0005 UNMARKED FILLETS/CHAMFER .06 DE-BURR ALL PARTS		DRAWN BY:	EMM 3/19/2020
<b>PROPRIETARY AND CONFIDENTIAL</b>		INTERPRET GEOMETRIC TOLERANCING PER: ASME Y14.5			
THE INFORMATION CONTAINED IN THIS DRAWING IS THE SOLE PROPERTY OF LASERLINC, INC. ANY REPRODUCTION IN PART OR AS A WHOLE WITHOUT THE WRITTEN PERMISSION OF LASERLINC, INC. IS PROHIBITED.		MATERIAL		63 RA SURFACE FINISH ALL FEATURES MUST MEET SPECIFICATION AFTER PLATING BEFORE POWDER-COAT IF PLATED OR POWDER-COATED <b>SEE FINISH</b>	
		FINISH		SIZE DWG. NO. REV	
		DO NOT SCALE DRAWING		B 6004-1145-01 B	
				SCALE: 1:1 SHEET 1 OF 5	



LASERLINC, INC.  
PHONE: 937-318-2440  
INFO@LASERLINC.COM  
WWW.LASERLINC.COM

TITLE:  
METRON-L UPPER MAGNET V-BLOCK HOLDER

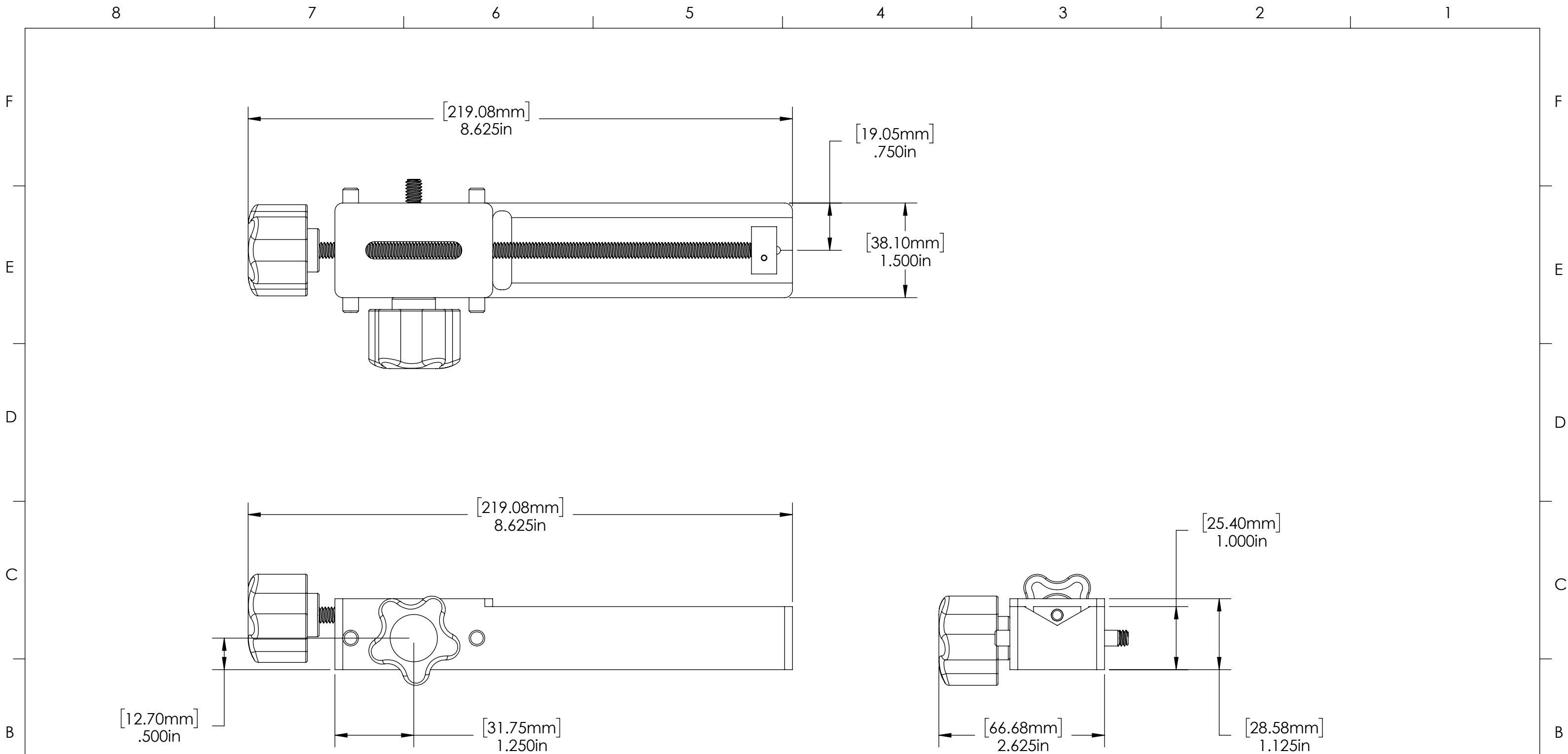

<b>GENERAL FINISH NOTE</b>	UNLESS OTHERWISE SPECIFIED:	NAME	DATE	 <b>LASERLINC, INC.</b> PHONE: 888-707-4892 INFO@LASERLINC.COM WWW.LASERLINC.COM
	<b>DE-BURR AND BREAK</b> <b>ALL SHARP EDGES</b> <b>BEFORE FINISH AND/OR SHIPPING</b>	DIMENSIONS ARE IN INCHES TOLERANCES: ANGLES ±.25° TWO PLACE DECIMAL ±0.010 THREE PLACE DECIMAL ±0.005 FOUR PLACE DECIMAL ±0.0005 UNMARKED FILLETS/CHAMFER .06 DE-BURR ALL PARTS	DRAWN BY:	
<b>PROPRIETARY AND CONFIDENTIAL</b>	INTERPRET GEOMETRIC TOLERANCING PER: ASME Y14.5	TITLE: METRON-L UPPER MAGNET V-BLOCK HOLDER		
THE INFORMATION CONTAINED IN THIS DRAWING IS THE SOLE PROPERTY OF LASERLINC, INC. ANY REPRODUCTION IN PART OR AS A WHOLE WITHOUT THE WRITTEN PERMISSION OF LASERLINC, INC. IS PROHIBITED.	MATERIAL	63 RA SURFACE FINISH ALL FEATURES MUST MEET SPECIFICATION AFTER PLATING BEFORE POWDER-COAT IF PLATED OR POWDER-COATED <b>SEE FINISH</b>		
	FINISH			
	DO NOT SCALE DRAWING	SIZE	DWG. NO.	REV
		<b>B</b>	6004-1145-01	<b>B</b>
		SCALE: 2:3		SHEET 5 OF 5