

REVISIONS

ZONE	REV.	DESCRIPTION	DATE	APPROVED
	A	CHECK-IN	3/29/2021	EMM
	B	REMOVED 10-24 SCREWS AND HOLES. ADDED CAPTIVE STUD, KNOB & THREAD REDUCER	11/5/2021	EMM

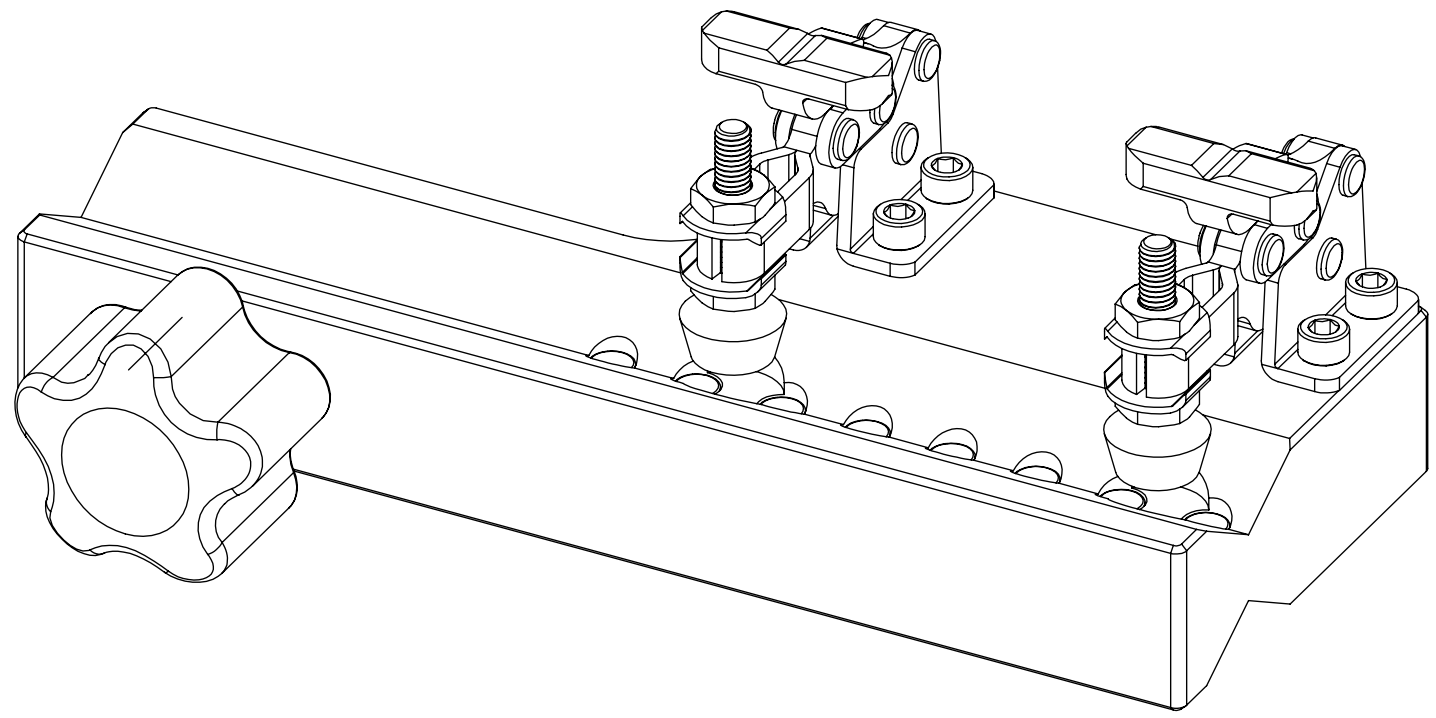



METRON UPPER SIDE TOGGLE CLAMP V-BLOCK ASSEMBLY

INDEX

- (1) COVER PAGE
- (2) BOM TABLE
- (3) ASSEMBLE HOME SIDE
- (4) MOUNT HOME SIDE
- (5) OVERALLS

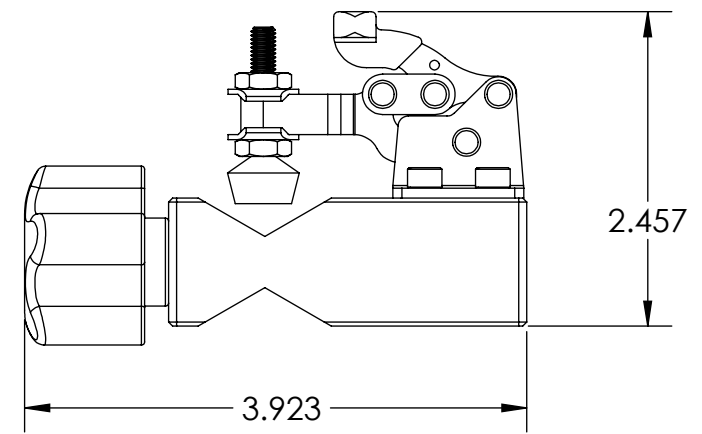
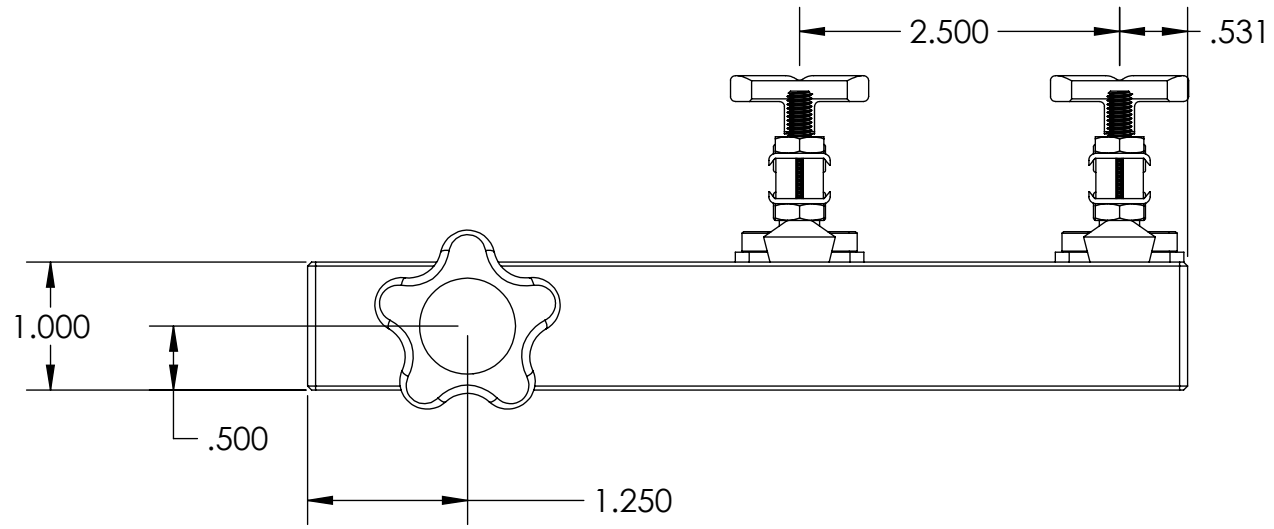
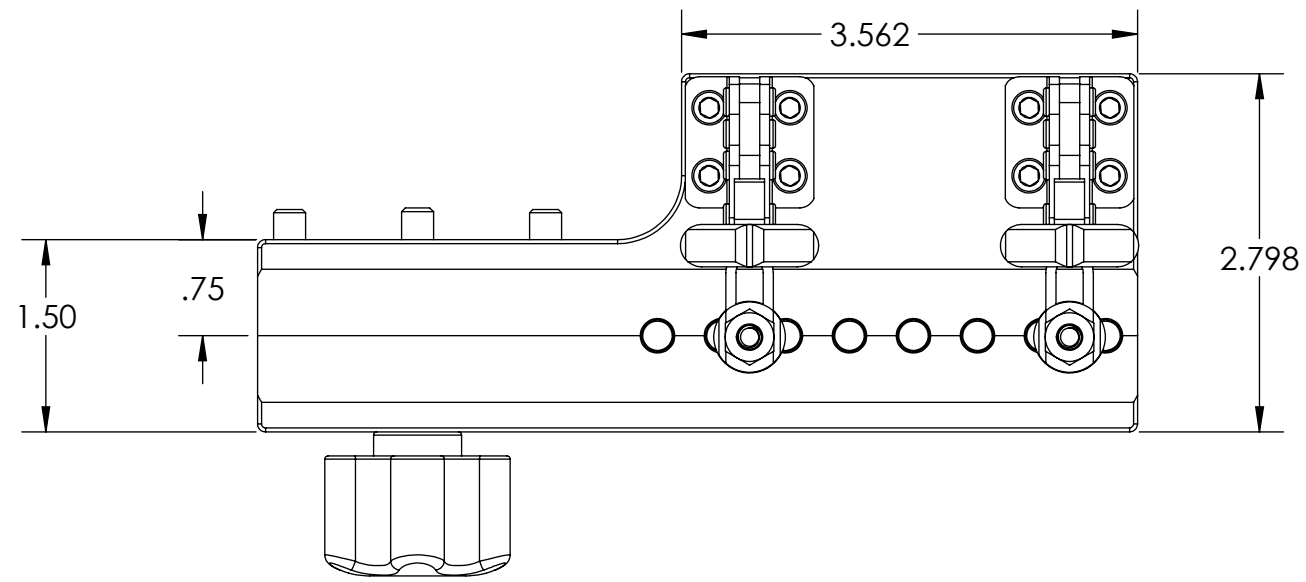
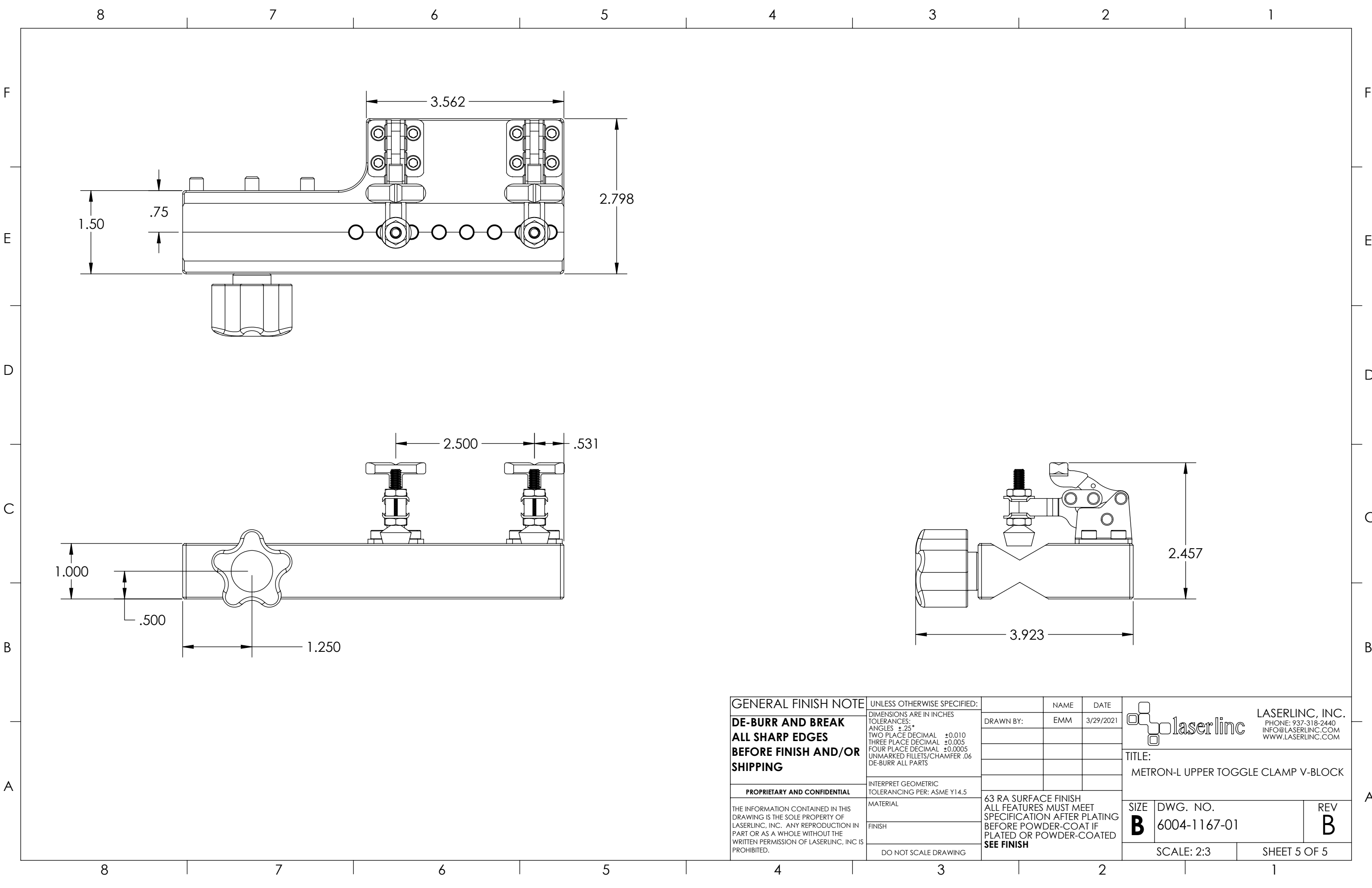
GENERAL FINISH NOTE		UNLESS OTHERWISE SPECIFIED:		NAME	DATE	 LASERLINC, INC. PHONE: 937-318-2440 INFO@LASERLINC.COM WWW.LASERLINC.COM
DE-BURR AND BREAK ALL SHARP EDGES BEFORE FINISH AND/OR SHIPPING		DIMENSIONS ARE IN INCHES TOLERANCES: ANGLES ±.25° TWO PLACE DECIMAL ±0.010 THREE PLACE DECIMAL ±0.005 FOUR PLACE DECIMAL ±0.0005 UNMARKED FILLETS/CHAMFER .06 DE-BURR ALL PARTS		DRAWN BY:	EMM	
PROPRIETARY AND CONFIDENTIAL		INTERPRET GEOMETRIC TOLERANCING PER: ASME Y14.5				
THE INFORMATION CONTAINED IN THIS DRAWING IS THE SOLE PROPERTY OF LASERLINC, INC. ANY REPRODUCTION IN PART OR AS A WHOLE WITHOUT THE WRITTEN PERMISSION OF LASERLINC, INC. IS PROHIBITED.		MATERIAL		63 RA SURFACE FINISH		TITLE: METRON-L UPPER TOGGLE CLAMP V-BLOCK
		FINISH		ALL FEATURES MUST MEET SPECIFICATION AFTER PLATING BEFORE POWDER-COAT IF PLATED OR POWDER-COATED		
		DO NOT SCALE DRAWING		SEE FINISH		SIZE B DWG. NO. 6004-1167-01 REV B
				SCALE: 1:1		SHEET 1 OF 5



GENERAL FINISH NOTE		UNLESS OTHERWISE SPECIFIED:		NAME	DATE	 LASERLINC, INC. PHONE: 937-318-2440 INFO@LASERLINC.COM WWW.LASERLINC.COM
DE-BURR AND BREAK ALL SHARP EDGES BEFORE FINISH AND/OR SHIPPING		DIMENSIONS ARE IN INCHES TOLERANCES: ANGLES ±.25° TWO PLACE DECIMAL ±0.010 THREE PLACE DECIMAL ±0.005 FOUR PLACE DECIMAL ±0.0005 UNMARKED FILLETS/CHAMFER .06 DE-BURR ALL PARTS		DRAWN BY:	EMM	
PROPRIETARY AND CONFIDENTIAL THE INFORMATION CONTAINED IN THIS DRAWING IS THE SOLE PROPERTY OF LASERLINC, INC. ANY REPRODUCTION IN PART OR AS A WHOLE WITHOUT THE WRITTEN PERMISSION OF LASERLINC, INC. IS PROHIBITED.		INTERPRET GEOMETRIC TOLERANCING PER: ASME Y14.5		63 RA SURFACE FINISH ALL FEATURES MUST MEET SPECIFICATION AFTER PLATING BEFORE POWDER-COAT IF PLATED OR POWDER-COATED SEE FINISH		TITLE: METRON-L UPPER TOGGLE CLAMP V-BLOCK
		MATERIAL		SIZE B DWG. NO. 6004-1167-01 REV B		SCALE: 2:3 SHEET 5 OF 5
		FINISH				
		DO NOT SCALE DRAWING				