

REVISIONS

ZONE	REV.	DESCRIPTION	DATE	APPROVED
	A	CHECK-IN	1/5/2022	EMM
	B	CENTER LINE DIMMENSIONS CHANGED	3/9/2022	EMM

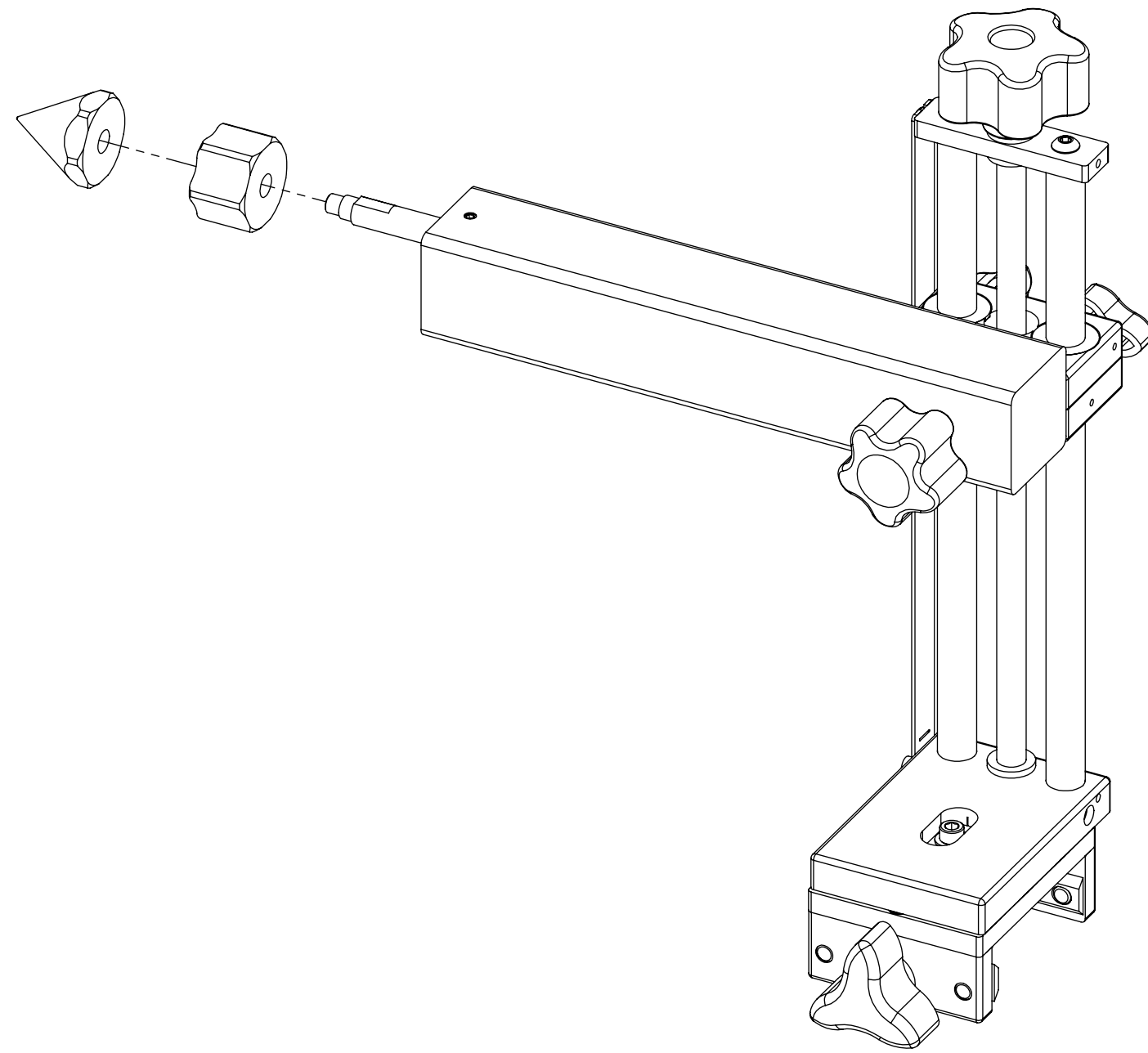

FIXED CENTER LIMIT SIDE OVERALLS

INDEX

- (1) COVER PAGE
- (2) DIMENSIONS

GENERAL FINISH NOTE DE-BURR AND BREAK ALL SHARP EDGES BEFORE FINISH AND/OR SHIPPING	UNLESS OTHERWISE SPECIFIED: DIMENSIONS ARE IN INCHES TOLERANCES: ANGLES ±.25 TWO PLACE DECIMAL ±0.010 THREE PLACE DECIMAL ±0.005 FOUR PLACE DECIMAL ±0.0005 UNMARKED FILLETS/CHAMFER .06 DE-BURR ALL PARTS	NAME EMM	DATE 1/5/2022	 LASERLINC, INC. PHONE: 888-707-4892 INFO@LASERLINC.COM WWW.LASERLINC.COM
	PROPRIETARY AND CONFIDENTIAL	INTERPRET GEOMETRIC TOLERANCING PER: ASME Y14.5	DRAWN BY:	
THE INFORMATION CONTAINED IN THIS DRAWING IS THE SOLE PROPERTY OF LASERLINC, INC. ANY REPRODUCTION IN PART OR AS A WHOLE WITHOUT THE WRITTEN PERMISSION OF LASERLINC, INC. IS PROHIBITED.	MATERIAL	63 RA SURFACE FINISH ALL FEATURES MUST MEET SPECIFICATION AFTER PLATING BEFORE POWDER-COAT IF PLATED OR POWDER-COATED SEE FINISH		SIZE B
DO NOT SCALE DRAWING	FINISH	DWG. NO. 6004-1181-01	REV B	SCALE: 1:2
				SHEET 1 OF 3

8 7 6 5 4 3 2 1

F

E

D

C

B

A

F

E

D

C

B

A

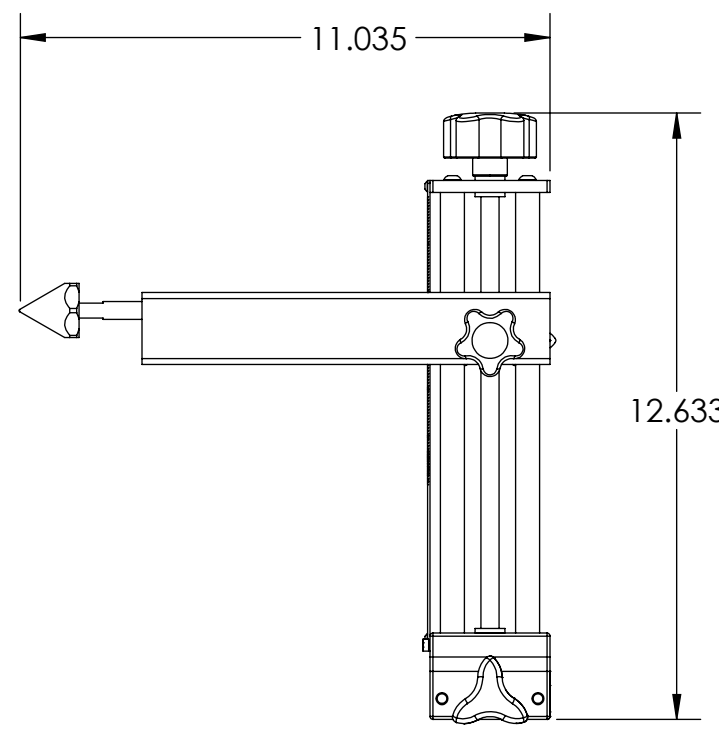
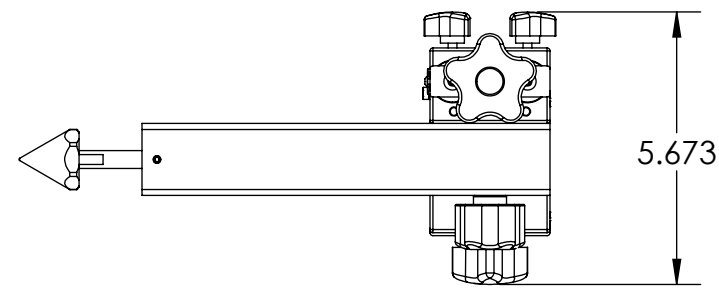
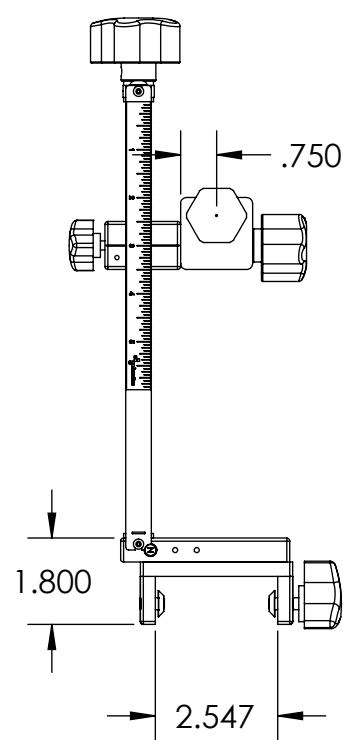

GENERAL FINISH NOTE DE-BURR AND BREAK ALL SHARP EDGES BEFORE FINISH AND/OR SHIPPING	UNLESS OTHERWISE SPECIFIED: DIMENSIONS ARE IN INCHES TOLERANCES: ANGLES ±.25 TWO PLACE DECIMAL ±0.010 THREE PLACE DECIMAL ±0.005 FOUR PLACE DECIMAL ±0.0005 UNMARKED FILLETS/CHAMFER .06 DE-BURR ALL PARTS	NAME EMM	DATE 1/5/2022	 LASERLINC, INC. PHONE: 888-707-4892 INFO@LASERLINC.COM WWW.LASERLINC.COM		
	PROPRIETARY AND CONFIDENTIAL	INTERPRET GEOMETRIC TOLERANCING PER: ASME Y14.5	TITLE: 6004-1181-01 FIXED CENTER LIMIT SIDE OVERALLS			
THE INFORMATION CONTAINED IN THIS DRAWING IS THE SOLE PROPERTY OF LASERLINC, INC. ANY REPRODUCTION IN PART OR AS A WHOLE WITHOUT THE WRITTEN PERMISSION OF LASERLINC, INC. IS PROHIBITED.	MATERIAL FINISH DO NOT SCALE DRAWING	63 RA SURFACE FINISH ALL FEATURES MUST MEET SPECIFICATION AFTER PLATING BEFORE POWDER-COAT IF PLATED OR POWDER-COATED SEE FINISH		SIZE B	DWG. NO. 6004-1181-01	REV B
		SCALE: 1:4		SHEET 2 OF 3		

8 7 6 5 4 3 2 1

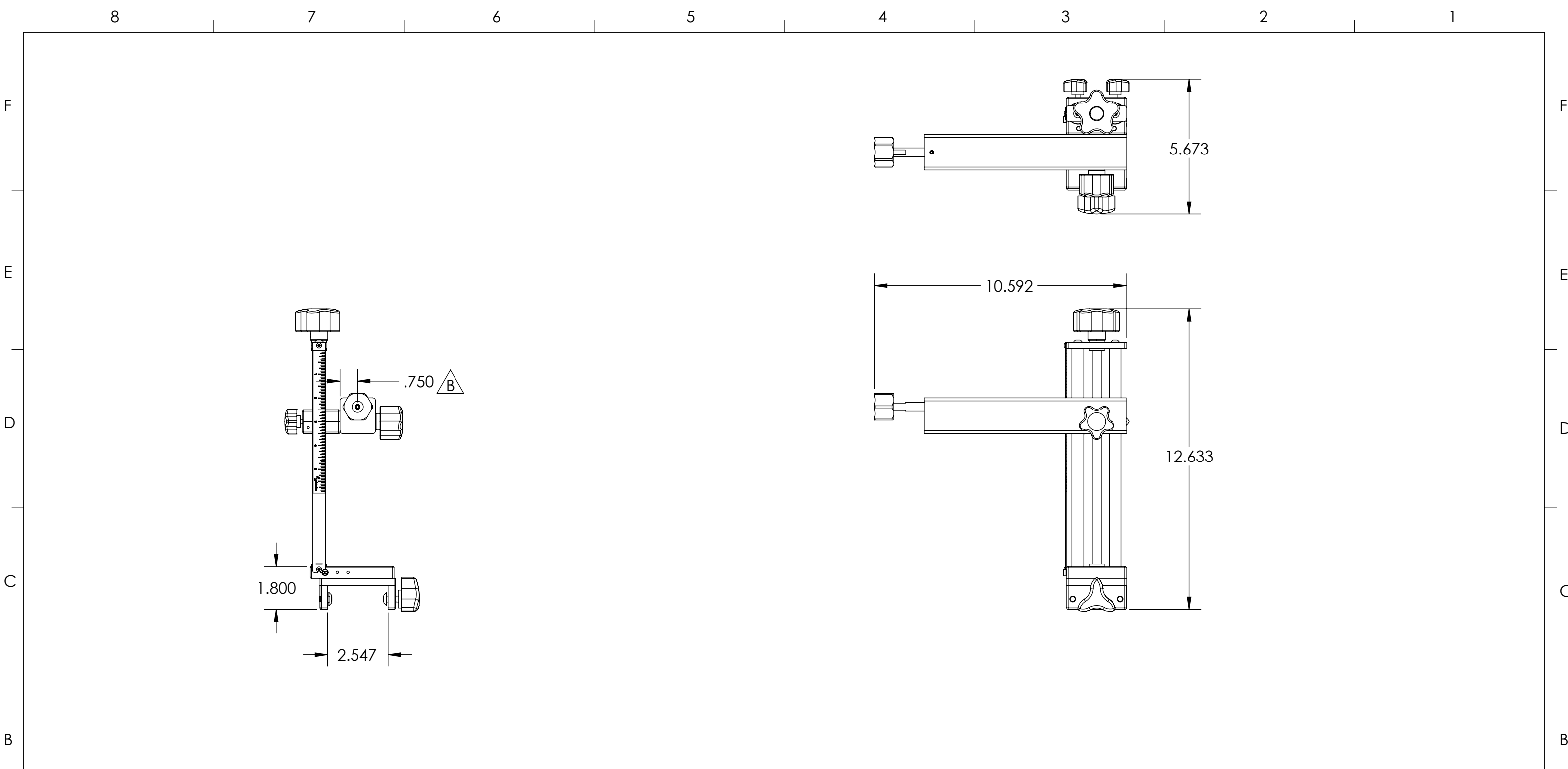

GENERAL FINISH NOTE DE-BURR AND BREAK ALL SHARP EDGES BEFORE FINISH AND/OR SHIPPING	UNLESS OTHERWISE SPECIFIED: DIMENSIONS ARE IN INCHES TOLERANCES: ANGLES ±.25 TWO PLACE DECIMAL ±0.010 THREE PLACE DECIMAL ±0.005 FOUR PLACE DECIMAL ±0.0005 UNMARKED FILLETS/CHAMFER .06 DE-BURR ALL PARTS	NAME EMM	DATE 1/5/2022	 LASERLINC, INC. PHONE: 888-707-4892 INFO@LASERLINC.COM WWW.LASERLINC.COM		
	PROPRIETARY AND CONFIDENTIAL	INTERPRET GEOMETRIC TOLERANCING PER: ASME Y14.5	DRAWN BY:		TITLE: 6004-1181-01 FIXED CENTER LIMIT SIDE OVERALLS	
THE INFORMATION CONTAINED IN THIS DRAWING IS THE SOLE PROPERTY OF LASERLINC, INC. ANY REPRODUCTION IN PART OR AS A WHOLE WITHOUT THE WRITTEN PERMISSION OF LASERLINC, INC. IS PROHIBITED.	MATERIAL FINISH DO NOT SCALE DRAWING	63 RA SURFACE FINISH ALL FEATURES MUST MEET SPECIFICATION AFTER PLATING BEFORE POWDER-COAT IF PLATED OR POWDER-COATED SEE FINISH		SIZE B	DWG. NO. 6004-1181-01	REV B
		SCALE: 1:4		SHEET 3 OF 3		