

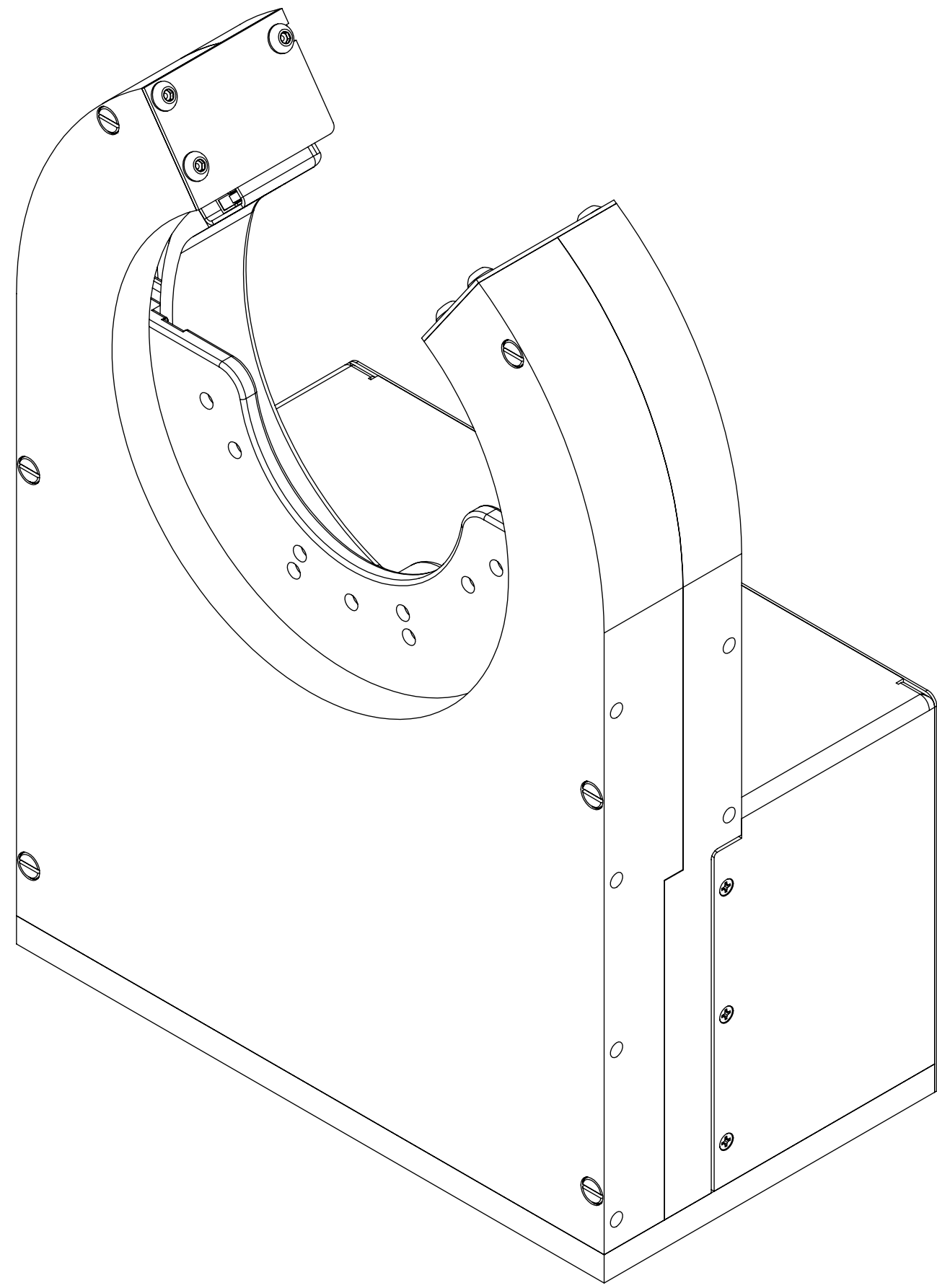

REVISIONS				
ZONE	REV.	DESCRIPTION	DATE	APPROVED
	A	Check-In	6/8/2012	MAM





ProfileVu Overall and Mounting Dimensions

INDEX

- (1) Cover Page
- (2) Dimensions

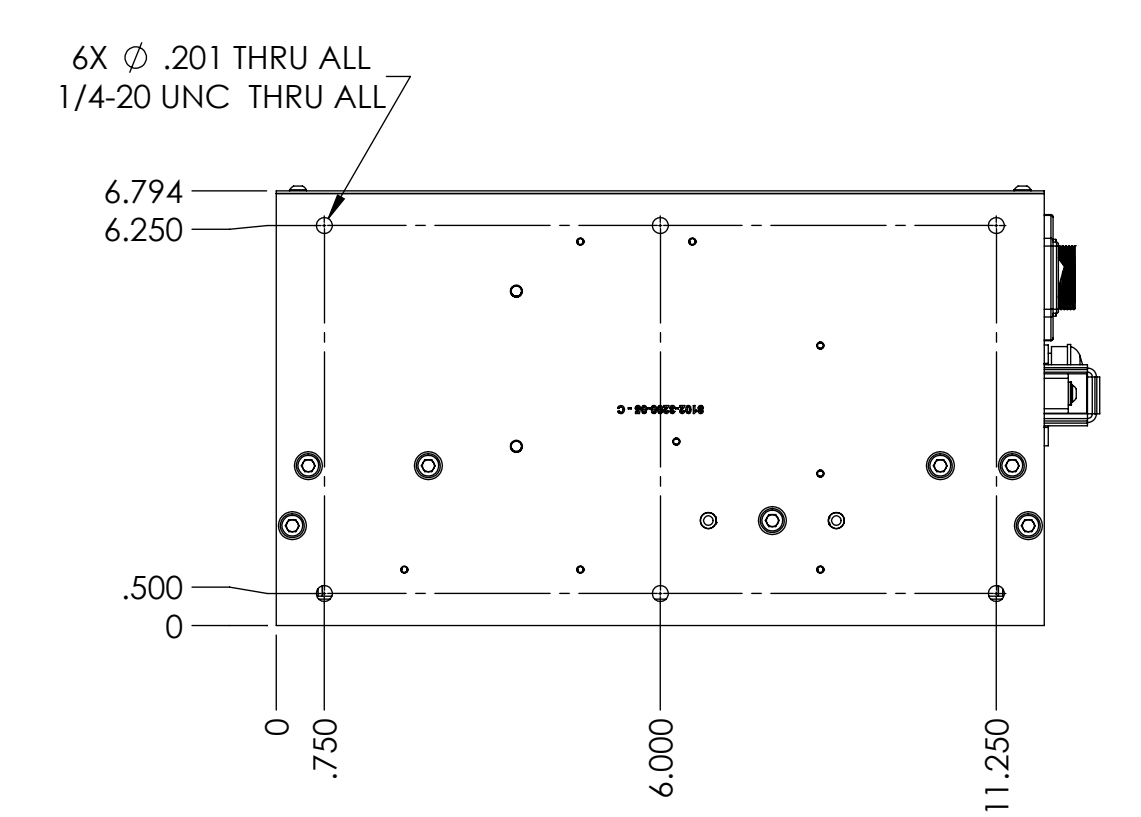
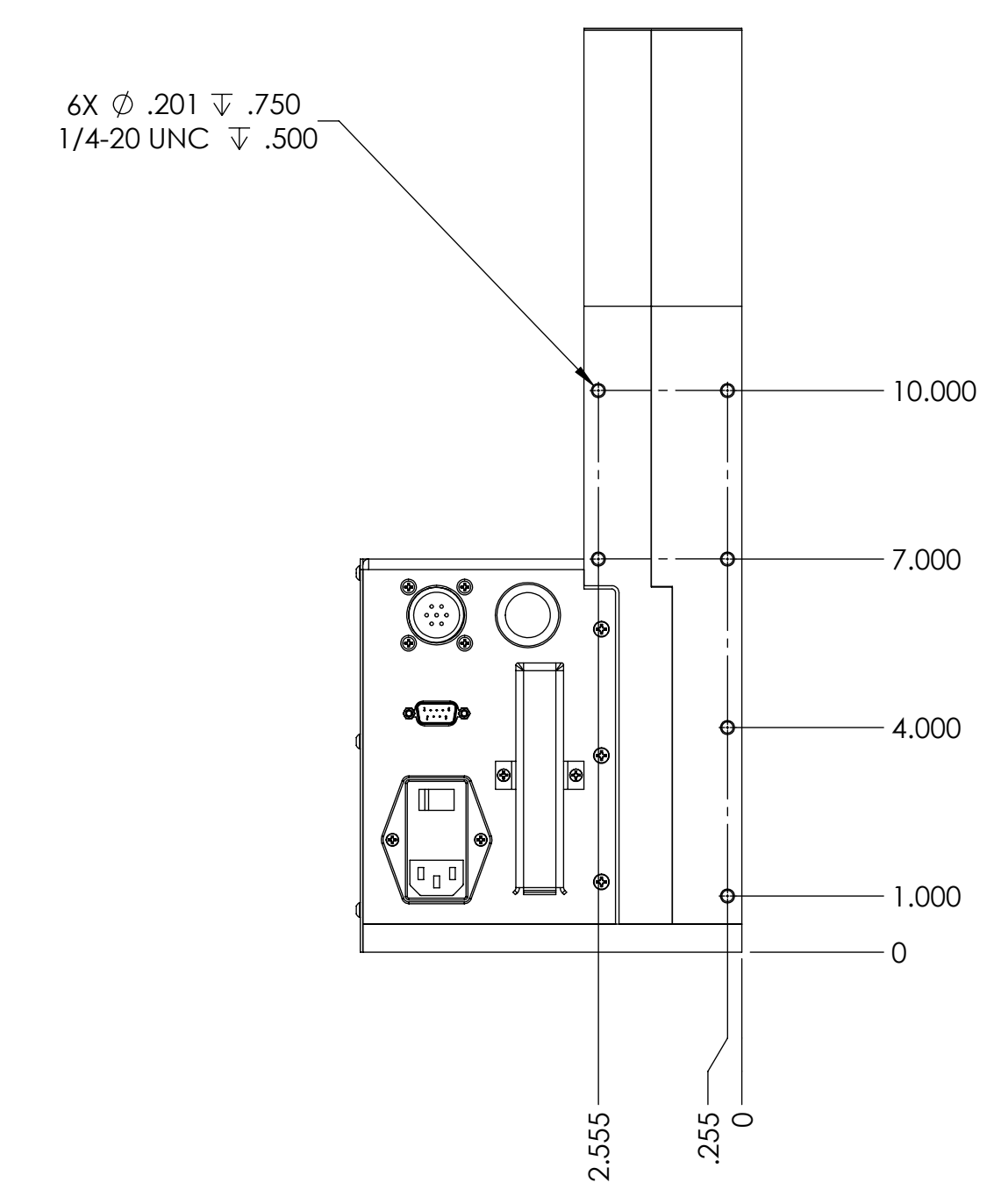
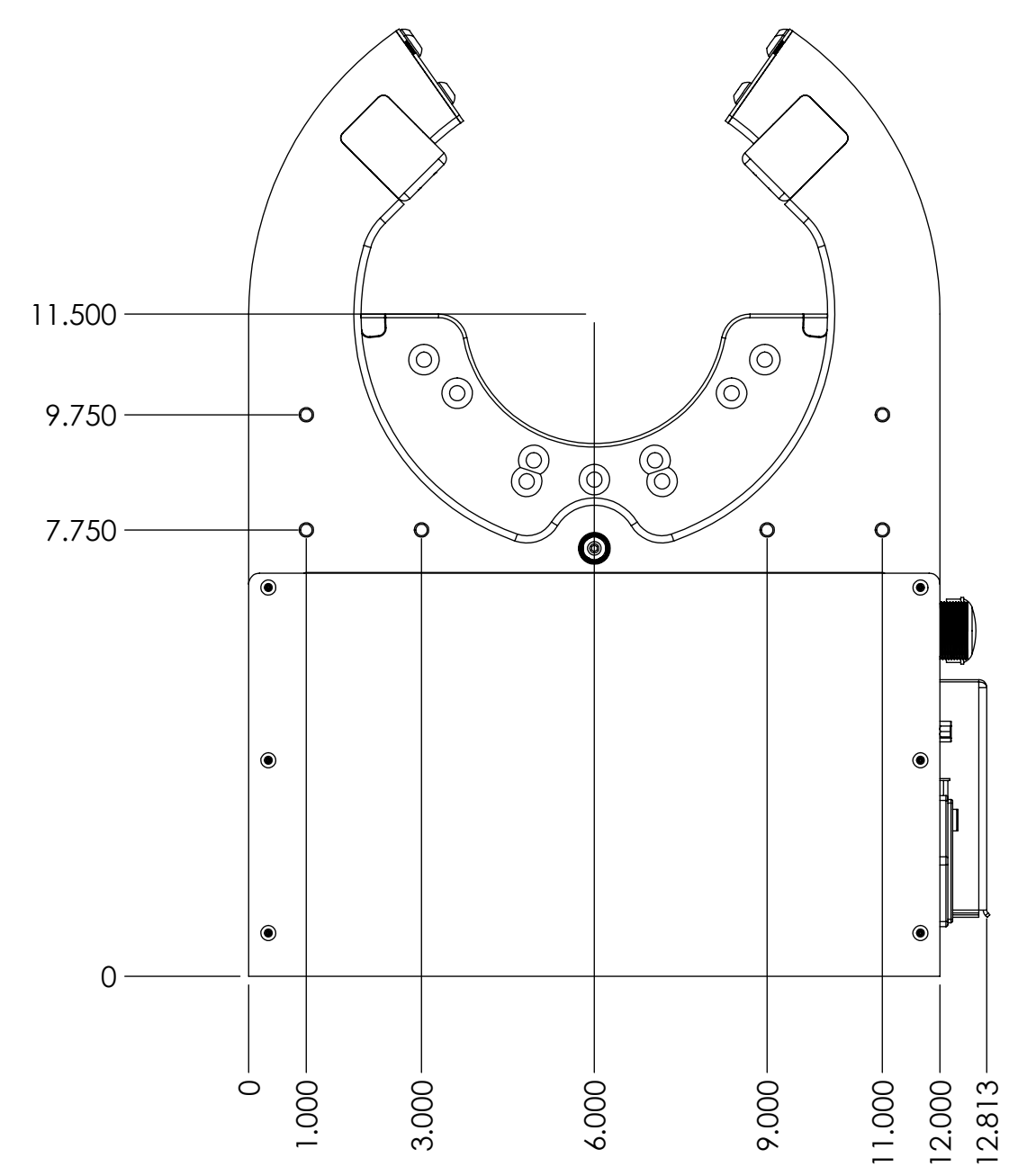
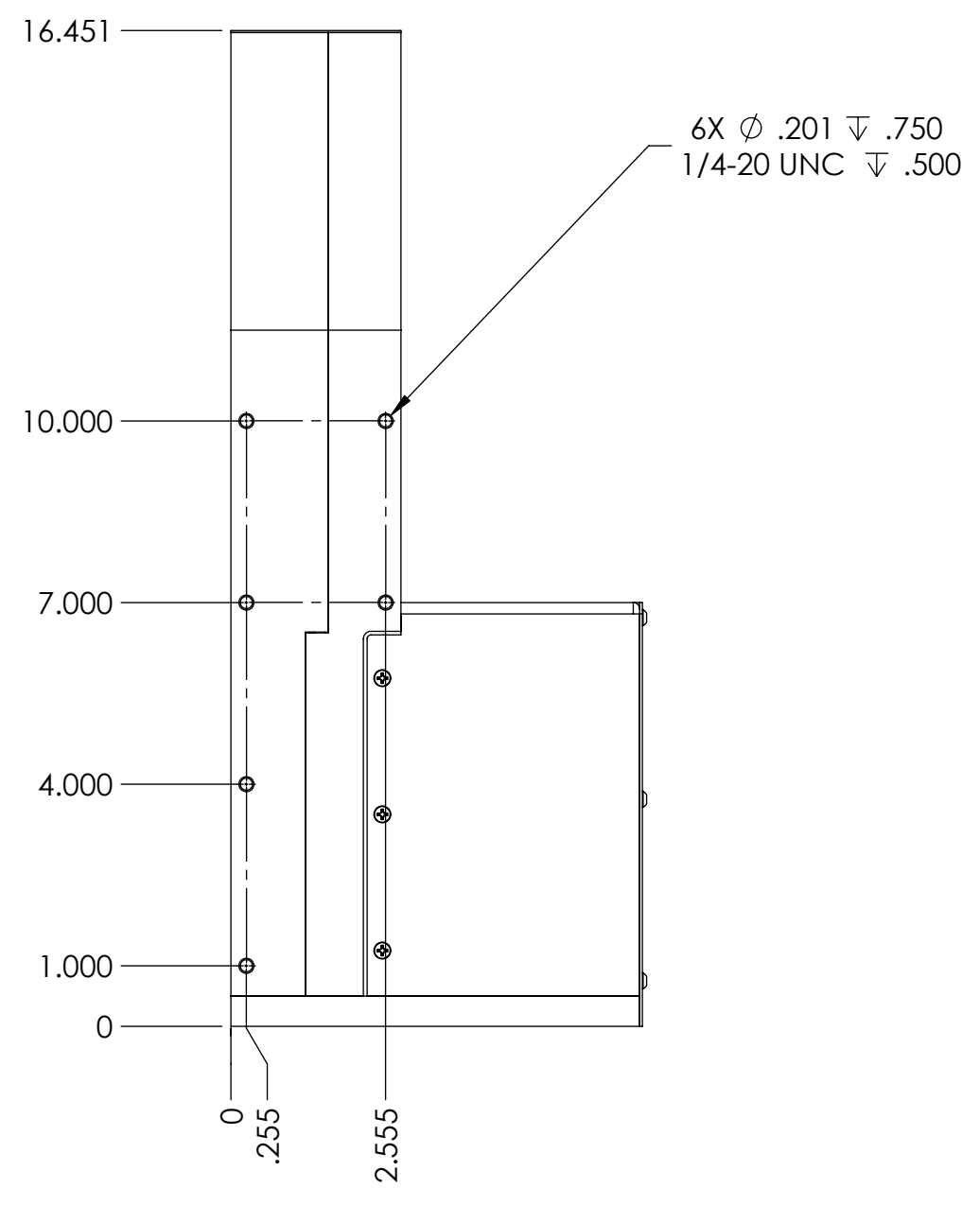
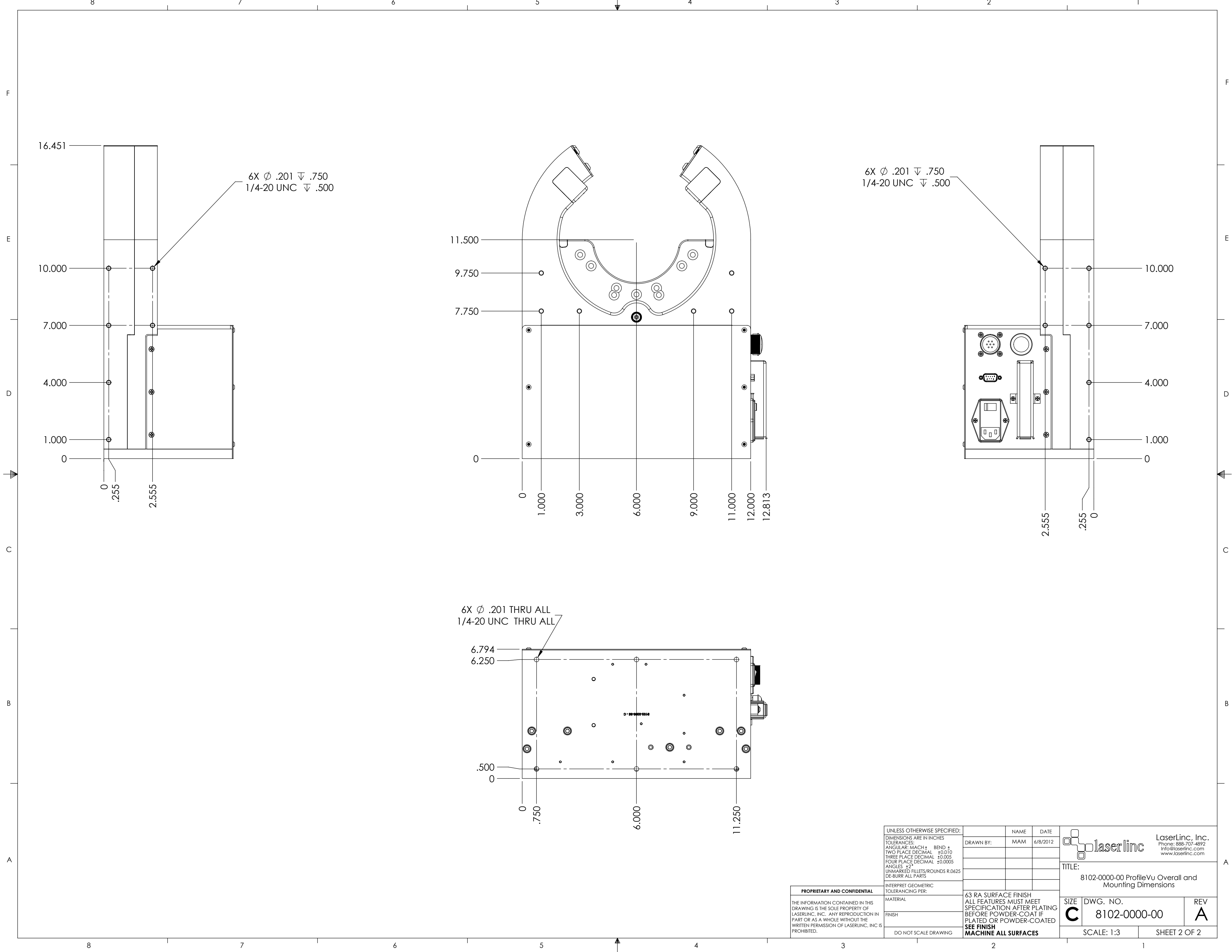
UNLESS OTHERWISE SPECIFIED: DIMENSIONS ARE IN INCHES TOLERANCES: ANGULAR: MACH ± BEND ± TWO PLACE DECIMAL ±0.010 THREE PLACE DECIMAL ±0.005 FOUR PLACE DECIMAL ±0.0005 ANGLES ±2° UNMARKED FILLETS/ROUNDS R.0625 DE-BURR ALL PARTS		NAME	DATE	 LaserLinc, Inc. Phone: 888-707-4892 info@laserlinc.com www.laserlinc.com
DRAWN BY: MAM		MAM	6/8/2012	
PROPRIETARY AND CONFIDENTIAL THE INFORMATION CONTAINED IN THIS DRAWING IS THE SOLE PROPERTY OF LASERLINC, INC. ANY REPRODUCTION IN PART OR AS A WHOLE WITHOUT THE WRITTEN PERMISSION OF LASERLINC, INC IS PROHIBITED.		INTERPRET GEOMETRIC TOLERANCING PER: MATERIAL: FINISH: DO NOT SCALE DRAWING		TITLE: 8102-0000-00 ProfileVu Overall and Mounting Dimensions
63 RA SURFACE FINISH ALL FEATURES MUST MEET SPECIFICATION AFTER PLATING BEFORE POWDER-COAT IF PLATED OR POWDER-COATED SEE FINISH MACHINE ALL SURFACES		SIZE C	DWG. NO. 8102-0000-00	REV A
		SCALE: 1:2		SHEET 1 OF 2



PROPRIETARY AND CONFIDENTIAL THE INFORMATION CONTAINED IN THIS DRAWING IS THE SOLE PROPERTY OF LASERLINC, INC. ANY REPRODUCTION IN PART OR AS A WHOLE WITHOUT THE WRITTEN PERMISSION OF LASERLINC, INC IS PROHIBITED.	UNLESS OTHERWISE SPECIFIED: DIMENSIONS ARE IN INCHES TOLERANCES: ANGULAR: MACH \pm BEND \pm TWO PLACE DECIMAL \pm 0.010 THREE PLACE DECIMAL \pm 0.005 FOUR PLACE DECIMAL \pm 0.0005 ANGLES \pm 2° UNMARKED FILLETS/ROUNDS R.0625 DE-BURR ALL PARTS	NAME MAM DATE 6/8/2012	 LaserLinc, Inc. Phone: 888-707-4892 info@laserlinc.com www.laserlinc.com
	INTERPRET GEOMETRIC TOLERANCING PER: MATERIAL FINISH DO NOT SCALE DRAWING	DRAWN BY: MAM	
63 RA SURFACE FINISH ALL FEATURES MUST MEET SPECIFICATION AFTER PLATING BEFORE POWDER-COAT IF PLATED OR POWDER-COATED SEE FINISH MACHINE ALL SURFACES		SIZE DWG. NO. C 8102-0000-00	REV A
		SCALE: 1:3	SHEET 2 OF 2