

REVISIONS

ZONE	REV.	DESCRIPTION	DATE	APPROVED
	A	CHECK-IN	12/23/2021	EMM
	B	CHANGED FRAME ASSEMBLE - SPLIT POWER RAIL - CE COMPLIANCE	3/27/2023	EMM

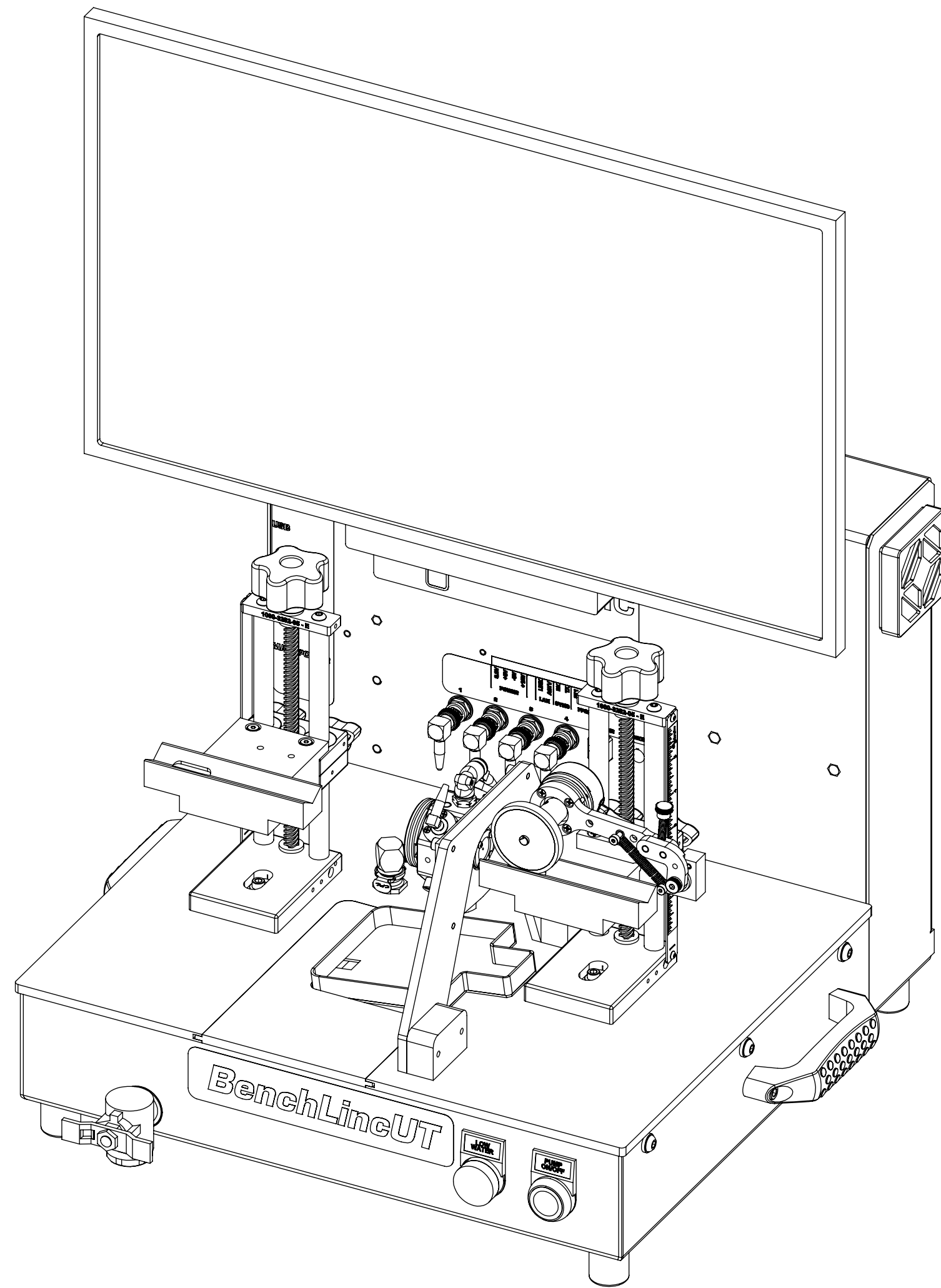

BENCHLINCUT412 - WALL ONLY BENCHTOP SYSTEM

INDEX

- (1) COVER PAGE
- (2) BOM TABLE 1
- (3) BOM TABLE 2
- (4) MOUNT HANDLE
- (5) PUMP ENCLOSURE & BUTTONS
- (6) MOUNT CHASSIS ELECTRONICS
- (7) MOUNT CHASSIS ELECTRONICS 2
- (8) MOUNT STICKERS
- (9) MOUNT FRONT PLATES
- (10) MOUNT CABINET ELECTRONICS 1
- (11) MOUNT CABINET ELECTRONICS 2
- (12) MOUNT DRY BLOCK & MICROMETER
- (13) MOUNT UPRIGHT & VESA MOUNT
- (14) MOUNT MONITOR & COVER
- (15) OVERALLS

GENERAL FINISH NOTE		UNLESS OTHERWISE SPECIFIED: DIMENSIONS ARE IN INCHES TOLERANCES: ANGLES ±.25° TWO PLACE DECIMAL ±0.010 THREE PLACE DECIMAL ±0.005 FOUR PLACE DECIMAL ±0.0005 UNMARKED FILLETS/CHAMFER .06 DE-BURR ALL PARTS	NAME	DATE	 LASERLINC, INC. PHONE: 937-318-2440 INFO@LASERLINC.COM WWW.LASERLINC.COM
DE-BURR AND BREAK ALL SHARP EDGES BEFORE FINISH AND/OR SHIPPING		INTERPRET GEOMETRIC TOLERANCING PER: ASME Y14.5	DRAWN BY:	EMM	
PROPRIETARY AND CONFIDENTIAL		MATERIAL	TITLE: BENCHLINC UT412 - WALL ONLY BENCHTOP MEASUREMENT SYSTEM		
THE INFORMATION CONTAINED IN THIS DRAWING IS THE SOLE PROPERTY OF LASERLINC, INC. ANY REPRODUCTION IN PART OR AS A WHOLE WITHOUT THE WRITTEN PERMISSION OF LASERLINC, INC IS PROHIBITED.		FINISH	63 RA SURFACE FINISH ALL FEATURES MUST MEET SPECIFICATION AFTER PLATING BEFORE POWDER-COAT IF PLATED OR POWDER-COATED SEE FINISH		
		DO NOT SCALE DRAWING	SIZE	DWG. NO.	REV
			C	4500-0002-00	B
			SCALE: 1:3		SHEET 1 OF 15

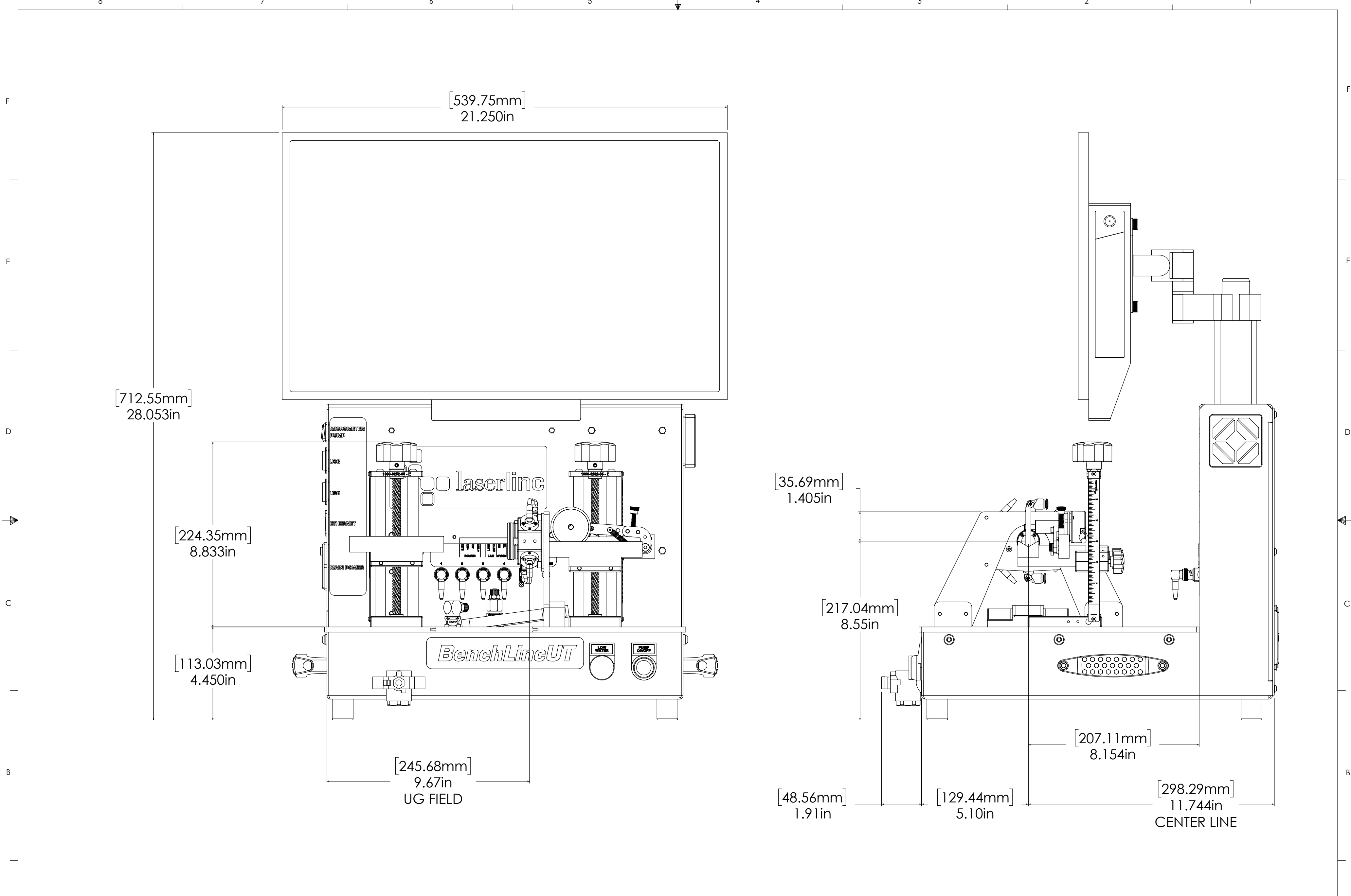

GENERAL FINISH NOTE		UNLESS OTHERWISE SPECIFIED: DIMENSIONS ARE IN INCHES		NAME	DATE
DE-BURR AND BREAK ALL SHARP EDGES BEFORE FINISH AND/OR SHIPPING		TOLERANCES: ANGLES ±.25° TWO PLACE DECIMAL ±0.010 THREE PLACE DECIMAL ±0.005 FOUR PLACE DECIMAL ±0.0005 UNMARKED FILLETS/CHAMFER .06 DE-BURR ALL PARTS		DRAWN BY:	EMM 12/23/2021
PROPRIETARY AND CONFIDENTIAL		INTERPRET GEOMETRIC TOLERANCING PER: ASME Y14.5			
THE INFORMATION CONTAINED IN THIS DRAWING IS THE SOLE PROPERTY OF LASERLINC, INC. ANY REPRODUCTION IN PART OR AS A WHOLE WITHOUT THE WRITTEN PERMISSION OF LASERLINC, INC IS PROHIBITED.		MATERIAL		63 RA SURFACE FINISH ALL FEATURES MUST MEET SPECIFICATION AFTER PLATING BEFORE POWDER-COAT IF PLATED OR POWDER-COATED SEE FINISH	
		FINISH		SIZE DWG. NO. REV	
		DO NOT SCALE DRAWING		C 4500-0002-00 B	
				SCALE: 1:3 SHEET 15 OF 15	



TITLE:
BENCHLINC UT412 - WALL ONLY BENCHTOP
MEASUREMENT SYSTEM