

8 7 6 5 4 3 2 1

REVISIONS				
ZONE	REV.	DESCRIPTION	DATE	APPROVED
	A	Check-in	10/22/2014	DRP

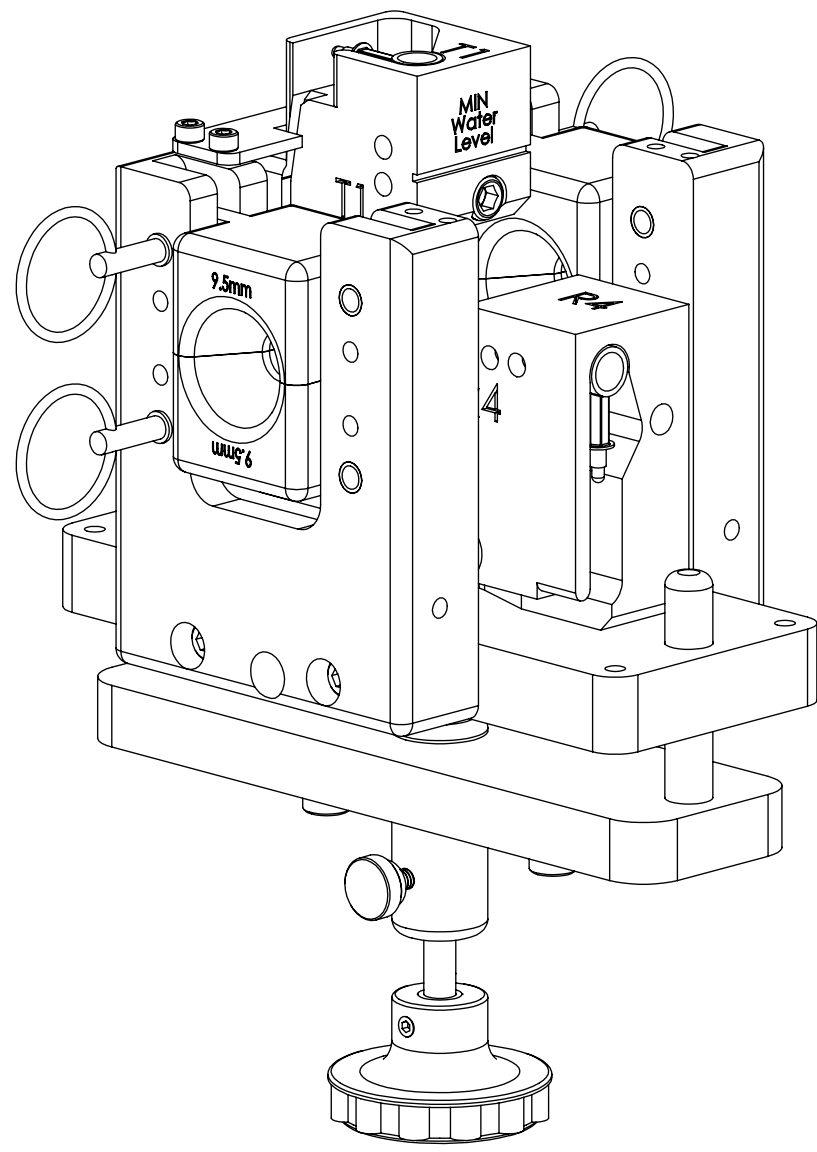

C4-38 Y-Adjust Vacuum Tank Assembly - Overalls

INDEX

- (1) Cover Page
- (2) Dimensions
- (3) Detailed View

UNLESS OTHERWISE SPECIFIED:		NAME	DATE
DIMENSIONS ARE IN INCHES		DRAWN BY:	DRP 10/22/2014
TOLERANCES:			
ANGULAR: MACH ± BEND ±			
TWO PLACE DECIMAL ±0.010			
THREE PLACE DECIMAL ±0.005			
FOUR PLACE DECIMAL ±0.0005			
ANGLES ±.25°			
UNMARKED FILLETS/ROUNDS R.0625			
DE-BURR ALL PARTS			
INTERPRET GEOMETRIC TOLERANCING PER:			
MATERIAL LL		63 RA SURFACE FINISH	
FINISH		ALL FEATURES MUST MEET SPECIFICATION AFTER PLATING BEFORE POWDER-COAT IF PLATED OR POWDER-COATED	
DO NOT SCALE DRAWING		SEE FINISH MACHINE ALL SURFACES	
LaserLinc, Inc. Phone: 888-707-4892 Info@laserlinc.com www.laserlinc.com		TITLE: 4009-0001-00 C4-38 Y-Adjust Vacuum Tank Assembly - Overalls	
SIZE B	DWG. NO. 04004-71	REV A	
SCALE: 2:3		SHEET 1 OF 3	

PROPRIETARY AND CONFIDENTIAL

THE INFORMATION CONTAINED IN THIS DRAWING IS THE SOLE PROPERTY OF LASERLINC, INC. ANY REPRODUCTION IN PART OR AS A WHOLE WITHOUT THE WRITTEN PERMISSION OF LASERLINC, INC IS PROHIBITED.

D
C
B
A

D
C
B
A

8 7 6 5 4 3 2 1

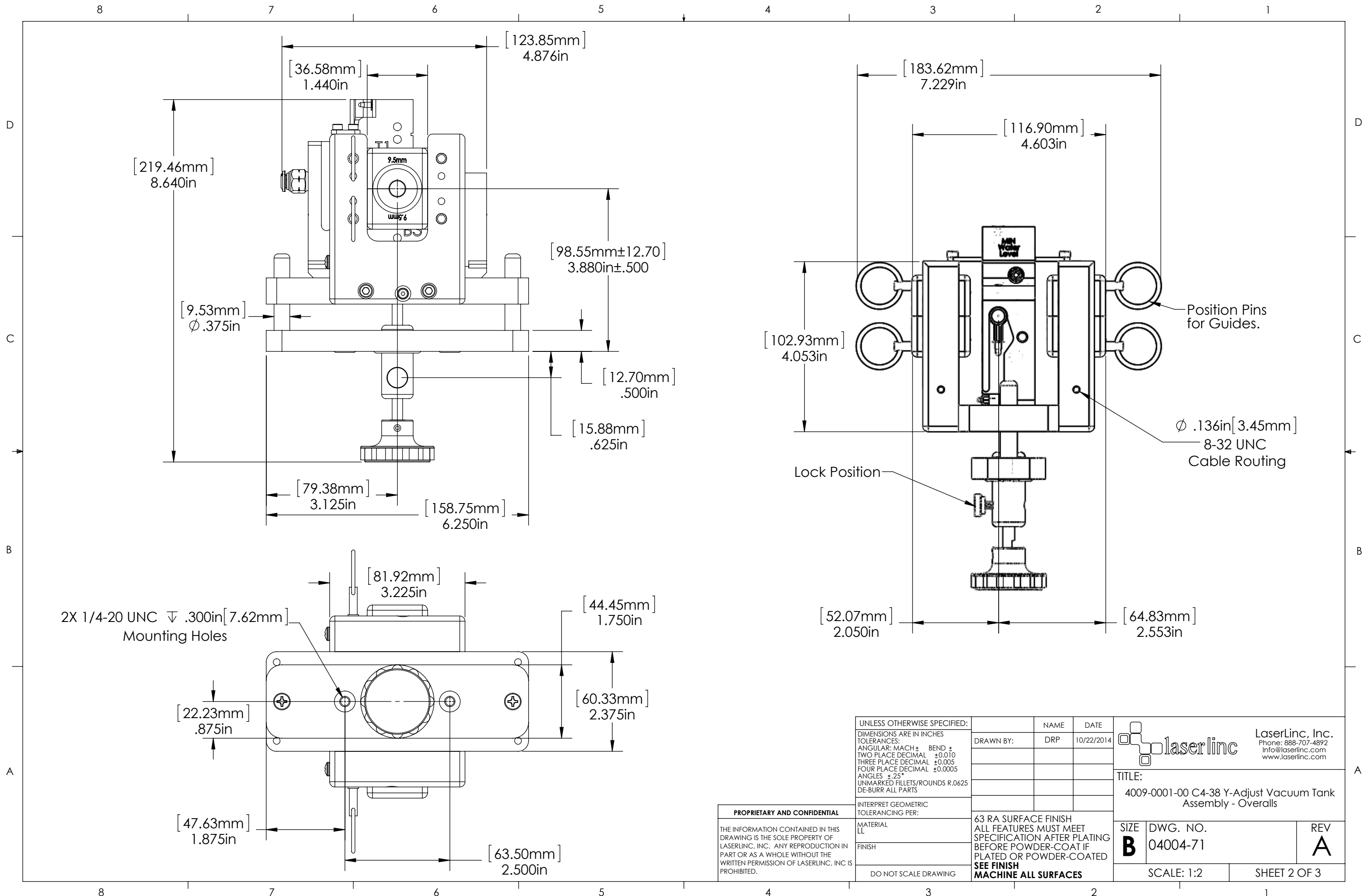

2X 1/4-20 UNC ∇ .300in [7.62mm]
Mounting Holes

PROPRIETARY AND CONFIDENTIAL	UNLESS OTHERWISE SPECIFIED:	NAME	DATE
	DIMENSIONS ARE IN INCHES	DRAWN BY:	DRP 10/22/2014
	TOLERANCES:		
	ANGULAR: MACH \pm BEND \pm TWO PLACE DECIMAL \pm 0.010 THREE PLACE DECIMAL \pm 0.005 FOUR PLACE DECIMAL \pm 0.0005 ANGLES \pm 25° UNMARKED FILLETS/ROUNDS R.0625 DE-BURR ALL PARTS		
	INTERPRET GEOMETRIC TOLERANCING PER:	63 RA SURFACE FINISH ALL FEATURES MUST MEET SPECIFICATION AFTER PLATING BEFORE POWDER-COAT IF PLATED OR POWDER-COATED SEE FINISH MACHINE ALL SURFACES	
	MATERIAL	LL	
	FINISH		
	DO NOT SCALE DRAWING		
LaserLinc, Inc. Phone: 888-707-4892 Info@laserlinc.com www.laserlinc.com		TITLE: 4009-0001-00 C4-38 Y-Adjust Vacuum Tank Assembly - Overalls	
SIZE	DWG. NO.	REV	
B	04004-71	A	
SCALE: 1:2		SHEET 2 OF 3	

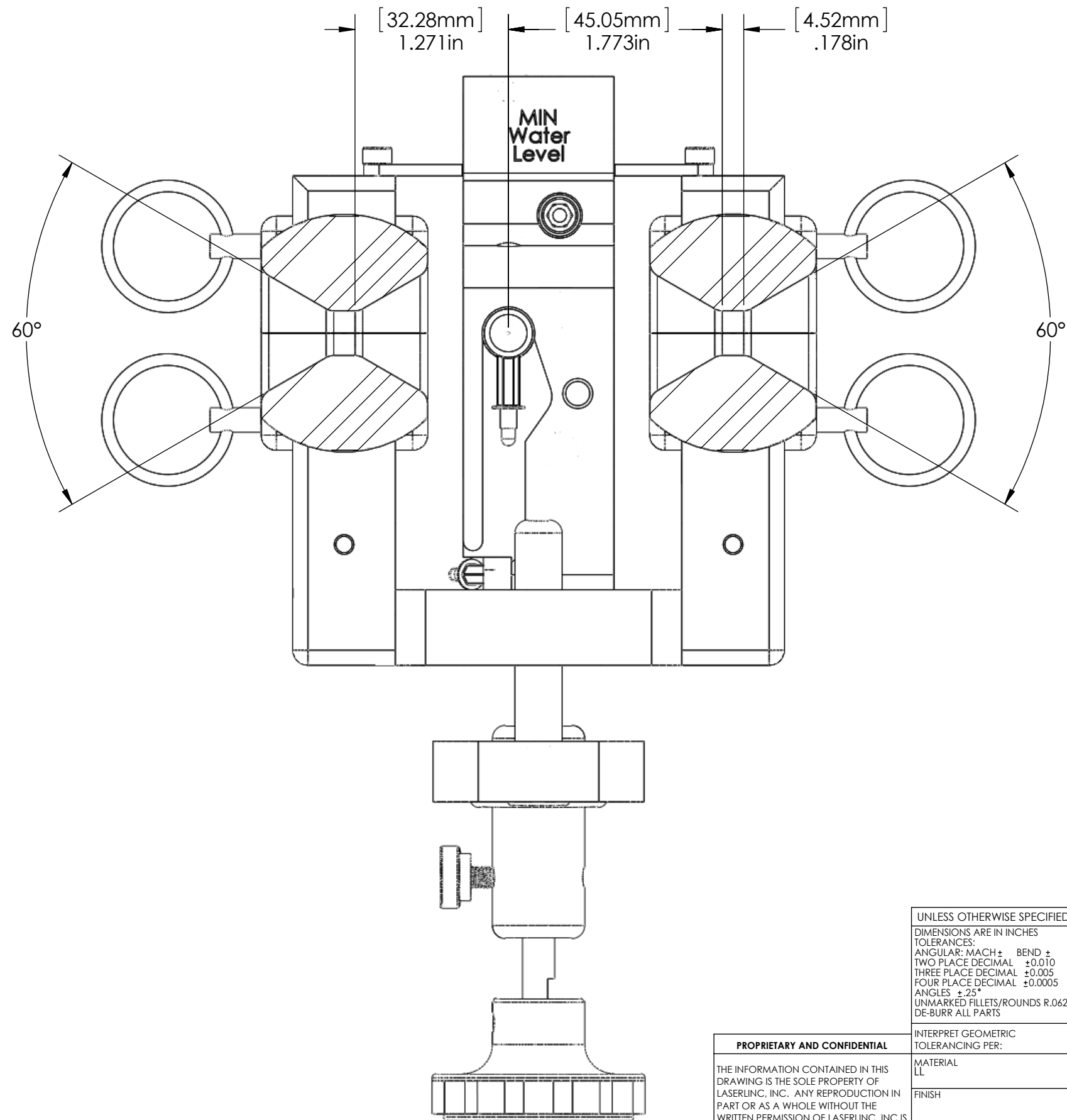

UNLESS OTHERWISE SPECIFIED:
 DIMENSIONS ARE IN INCHES
 TOLERANCES:
 ANGULAR: MACH ± BEND ±
 TWO PLACE DECIMAL ±0.010
 THREE PLACE DECIMAL ±0.005
 FOUR PLACE DECIMAL ±0.0005
 ANGLES ±.25°
 UNMARKED FILLETS/ROUNDS R.0625
 DE-BURR ALL PARTS

INTERPRET GEOMETRIC
 TOLERANCING PER:

MATERIAL
 LL

FINISH

DO NOT SCALE DRAWING

NAME	DATE
DRP	10/22/2014

63 RA SURFACE FINISH
 ALL FEATURES MUST MEET
 SPECIFICATION AFTER PLATING
 BEFORE POWDER-COAT IF
 PLATED OR POWDER-COATED
**SEE FINISH
 MACHINE ALL SURFACES**

PROPRIETARY AND CONFIDENTIAL
 THE INFORMATION CONTAINED IN THIS
 DRAWING IS THE SOLE PROPERTY OF
 LASERLINC, INC. ANY REPRODUCTION IN
 PART OR AS A WHOLE WITHOUT THE
 WRITTEN PERMISSION OF LASERLINC, INC IS
 PROHIBITED.

LaserLinc, Inc.
 Phone: 888-707-4892
 Info@laserlinc.com
 www.laserlinc.com

TITLE:
 4009-0001-00 C4-38 Y-Adjust Vacuum Tank
 Assembly - Overalls

SIZE B	DWG. NO. 04004-71	REV A
SCALE: 1:1		SHEET 3 OF 3