

8 7 6 5 4 3 2 1

REVISIONS				
ZONE	REV.	DESCRIPTION	DATE	APPROVED
	A	Check-in	11/16/2012	DRP

D
C
B
A

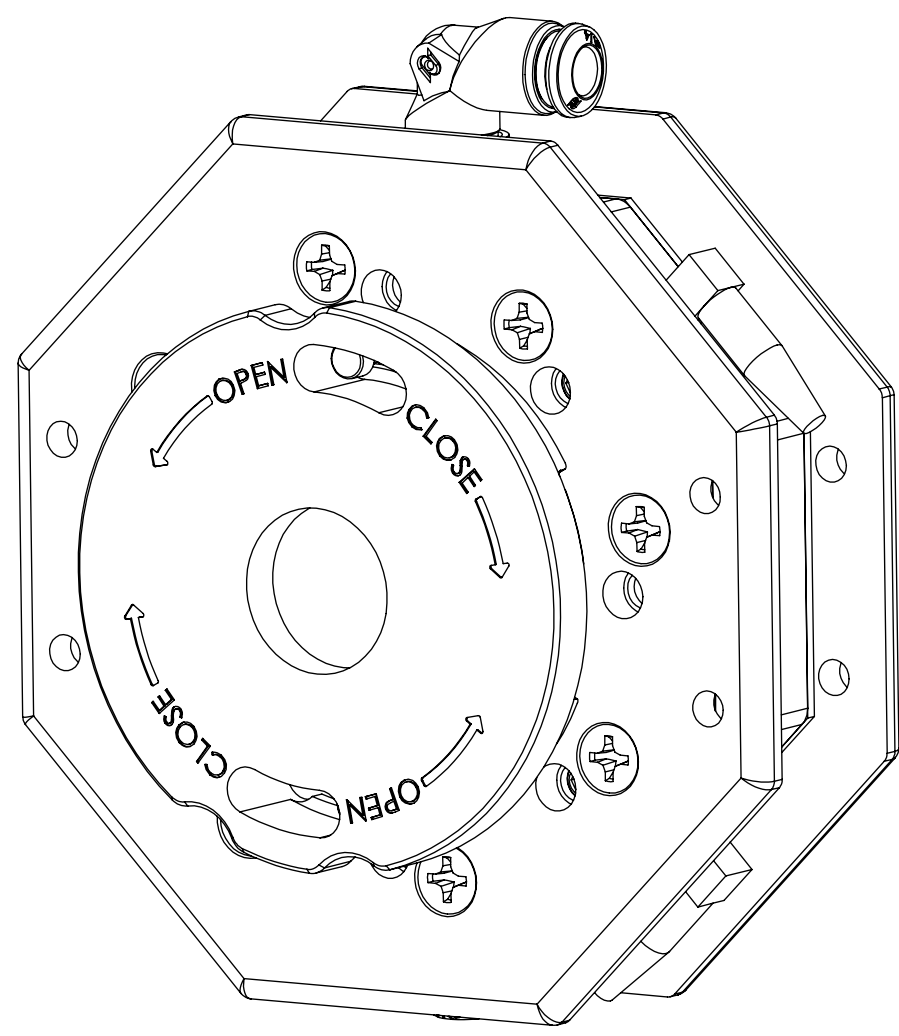

Ring4-19SC Assembly Overalls

INDEX

- (1) Cover Page
- (2) General Dimensions
- (3) Detailed Views

UNLESS OTHERWISE SPECIFIED:		NAME	DATE	 LaserLinc, Inc. Phone: 888-707-4892 Info@laserlinc.com www.laserlinc.com
DIMENSIONS ARE IN INCHES TOLERANCES: ANGULAR: MACH ± BEND ± TWO PLACE DECIMAL ±0.010 THREE PLACE DECIMAL ±0.005 FOUR PLACE DECIMAL ±0.0005 ANGLES ±.25° UNMARKED FILLETS/ROUNDS R.0625 DE-BURR ALL PARTS		DRAWN BY:	DRP	
PROPRIETARY AND CONFIDENTIAL THE INFORMATION CONTAINED IN THIS DRAWING IS THE SOLE PROPERTY OF LASERLINC, INC. ANY REPRODUCTION IN PART OR AS A WHOLE WITHOUT THE WRITTEN PERMISSION OF LASERLINC, INC IS PROHIBITED.		INTERPRET GEOMETRIC TOLERANCING PER: MATERIAL FINISH DO NOT SCALE DRAWING		TITLE: 4021-0000-00 Ring4-19SC Assembly Overalls
		63 RA SURFACE FINISH ALL FEATURES MUST MEET SPECIFICATION AFTER PLATING BEFORE POWDER-COAT IF PLATED OR POWDER-COATED SEE FINISH MACHINE ALL SURFACES		SIZE B
		DWG. NO. 4021-0000-00		REV A
		SCALE: 1:1		SHEET 1 OF 3

8 7 6 5 4 3 2 1

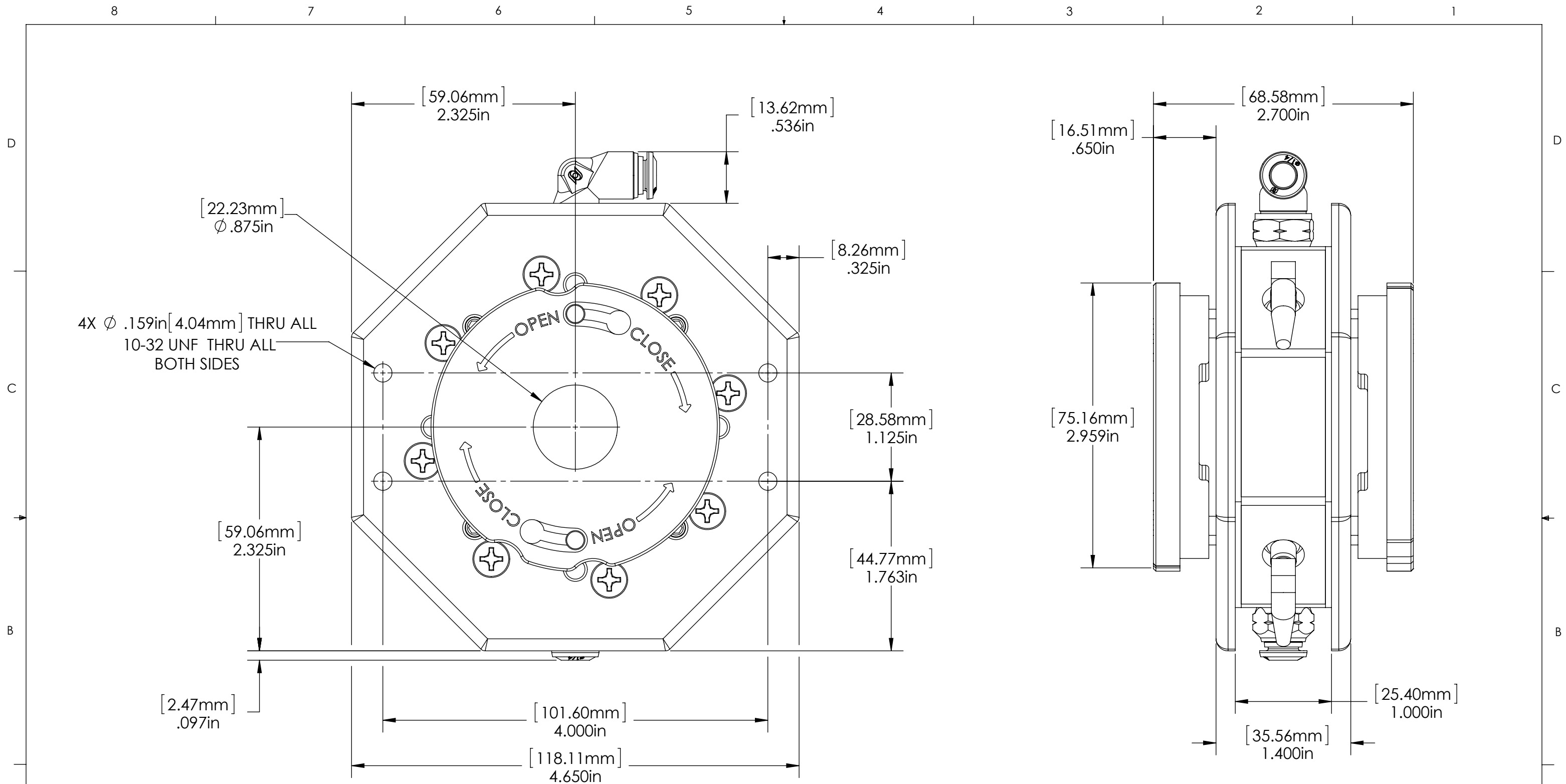

4X Ø .159in [4.04mm] THRU ALL
10-32 UNF THRU ALL
BOTH SIDES

UNLESS OTHERWISE SPECIFIED:
DIMENSIONS ARE IN INCHES
TOLERANCES:
ANGULAR: MACH ± BEND ±
TWO PLACE DECIMAL ±0.010
THREE PLACE DECIMAL ±0.005
FOUR PLACE DECIMAL ±0.0005
ANGLES ±.25°
UNMARKED FILLETS/ROUNDS R.0625
DE-BURR ALL PARTS

PROPRIETARY AND CONFIDENTIAL
THE INFORMATION CONTAINED IN THIS
DRAWING IS THE SOLE PROPERTY OF
LASERLINC, INC. ANY REPRODUCTION IN
PART OR AS A WHOLE WITHOUT THE
WRITTEN PERMISSION OF LASERLINC, INC IS
PROHIBITED.

INTERPRET GEOMETRIC
TOLERANCING PER:
MATERIAL
FINISH
DO NOT SCALE DRAWING

NAME	DATE
DRP	11/16/2012

63 RA SURFACE FINISH
ALL FEATURES MUST MEET
SPECIFICATION AFTER PLATING
BEFORE POWDER-COAT IF
PLATED OR POWDER-COATED
SEE FINISH
MACHINE ALL SURFACES

laserlinc LaserLinc, Inc.
Phone: 888-707-4892
Info@laserlinc.com
www.laserlinc.com

TITLE:
4021-0000-00 Ring4-19SC Assembly Overalls

SIZE B	DWG. NO. 4021-0000-00	REV A
SCALE: 1:1		SHEET 2 OF 3

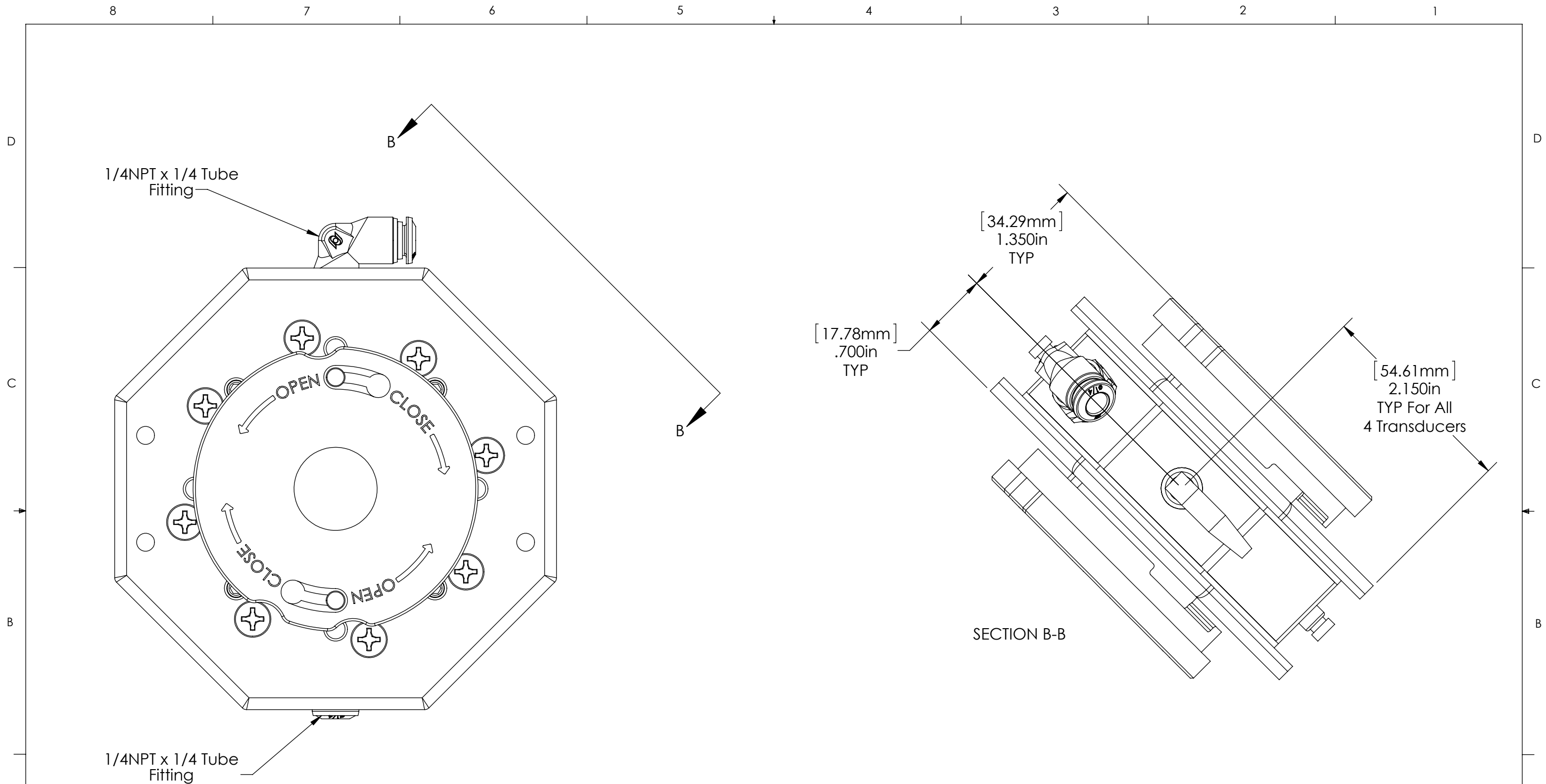

UNLESS OTHERWISE SPECIFIED:
 DIMENSIONS ARE IN INCHES
 TOLERANCES:
 ANGULAR: MACH ± BEND ±
 TWO PLACE DECIMAL ±0.010
 THREE PLACE DECIMAL ±0.005
 FOUR PLACE DECIMAL ±0.0005
 ANGLES ±.25°
 UNMARKED FILLETS/ROUNDS R.0625
 DE-BURR ALL PARTS

PROPRIETARY AND CONFIDENTIAL
 THE INFORMATION CONTAINED IN THIS DRAWING IS THE SOLE PROPERTY OF LASERLINC, INC. ANY REPRODUCTION IN PART OR AS A WHOLE WITHOUT THE WRITTEN PERMISSION OF LASERLINC, INC IS PROHIBITED.

INTERPRET GEOMETRIC TOLERANCING PER:
 MATERIAL
 FINISH
 DO NOT SCALE DRAWING

NAME	DATE
DRP	11/16/2012

63 RA SURFACE FINISH
 ALL FEATURES MUST MEET SPECIFICATION AFTER PLATING BEFORE POWDER-COAT IF PLATED OR POWDER-COATED SEE FINISH MACHINE ALL SURFACES



LaserLinc, Inc.
 Phone: 888-707-4892
 Info@laserlinc.com
 www.laserlinc.com

TITLE:
 4021-0000-00 Ring4-19SC Assembly Overalls

SIZE B	DWG. NO. 4021-0000-00	REV A
SCALE: 1:1		SHEET 3 OF 3