

8

7

6

5

4

3

2

1

F

E

D

C

B

A

F

E

D

C

B

A

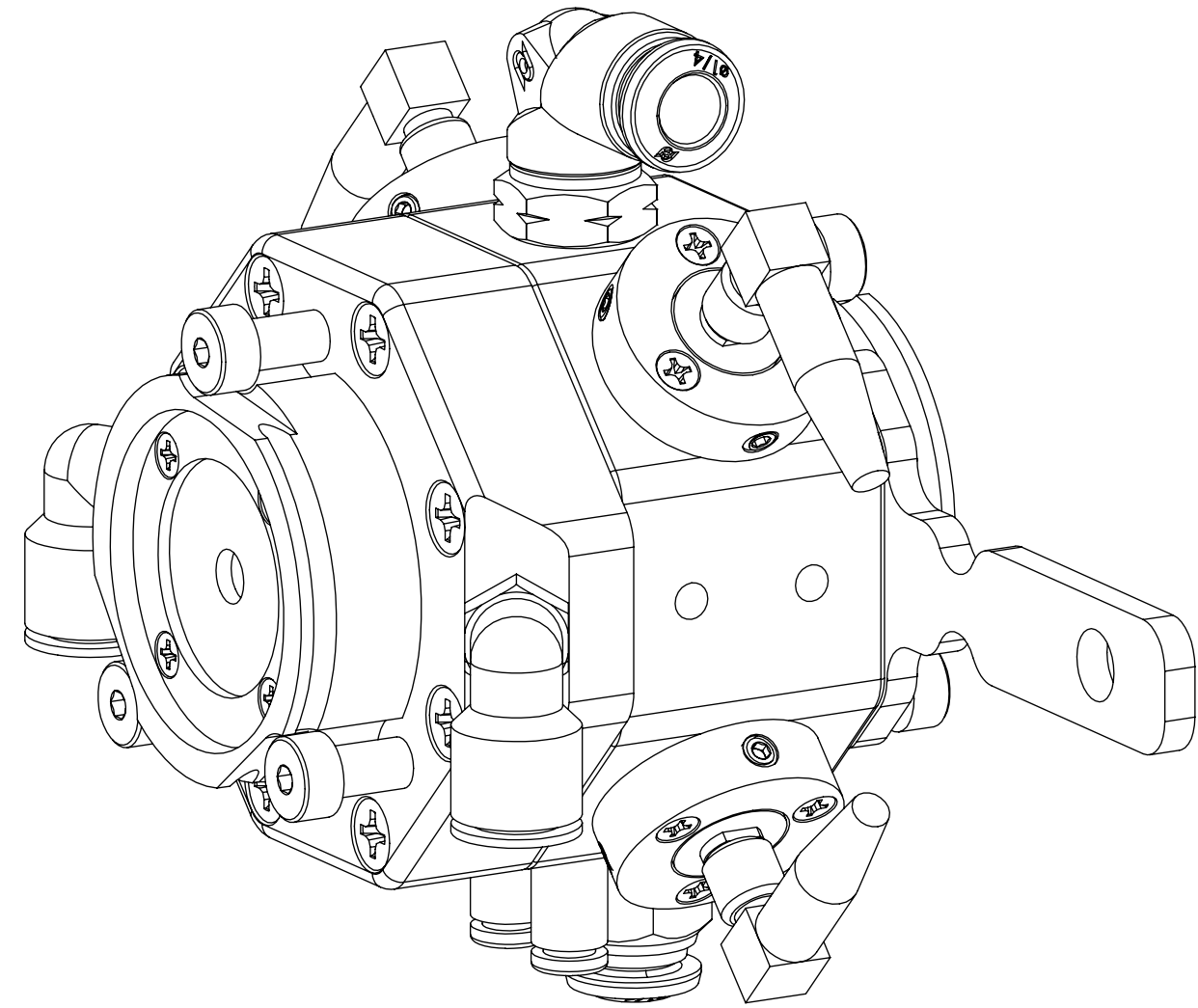

REVISIONS				
ZONE	REV.	DESCRIPTION	DATE	APPROVED
	A	CHECK-IN	4/3/2013	DRP

R4-8SC PIVOTING TRANSDUCER ASSEMBLY OVERALLS

INDEX

- (1) COVER PAGE
- (2) OVERALL DIMENSIONS
- (3) THINGS TO KNOW

GENERAL FINISH NOTE		UNLESS OTHERWISE SPECIFIED:		NAME	DATE	 LASERLINC, INC. PHONE: 888-707-4892 INFO@LASERLINC.COM WWW.LASERLINC.COM
DE-BURR AND BREAK ALL SHARP EDGES BEFORE FINISH AND/OR SHIPPING		DIMENSIONS ARE IN INCHES TOLERANCES: ANGLES ±.25° TWO PLACE DECIMAL ±0.010 THREE PLACE DECIMAL ±0.005 FOUR PLACE DECIMAL ±0.0005 UNMARKED FILLETS/CHAMFER .06 DE-BURR ALL PARTS		DRAWN BY:	DRP	
PROPRIETARY AND CONFIDENTIAL		INTERPRET GEOMETRIC TOLERANCING PER: ASME Y14.5				
THE INFORMATION CONTAINED IN THIS DRAWING IS THE SOLE PROPERTY OF LASERLINC, INC. ANY REPRODUCTION IN PART OR AS A WHOLE WITHOUT THE WRITTEN PERMISSION OF LASERLINC, INC. IS PROHIBITED.		MATERIAL		63 RA SURFACE FINISH ALL FEATURES MUST MEET SPECIFICATION AFTER PLATING BEFORE POWDER-COAT IF PLATED OR POWDER-COATED SEE FINISH		TITLE:
		FINISH NONE				4021-0002-00 R4-8SC PIVOTING TRANSDUCER ASSEMBLY OVERALLS
		DO NOT SCALE DRAWING				SIZE B
						DWG. NO. 4021-0002-00
						REV B
						SCALE: 3:2
						SHEET 1 OF 3

8

7

6

5

4

3

2

1

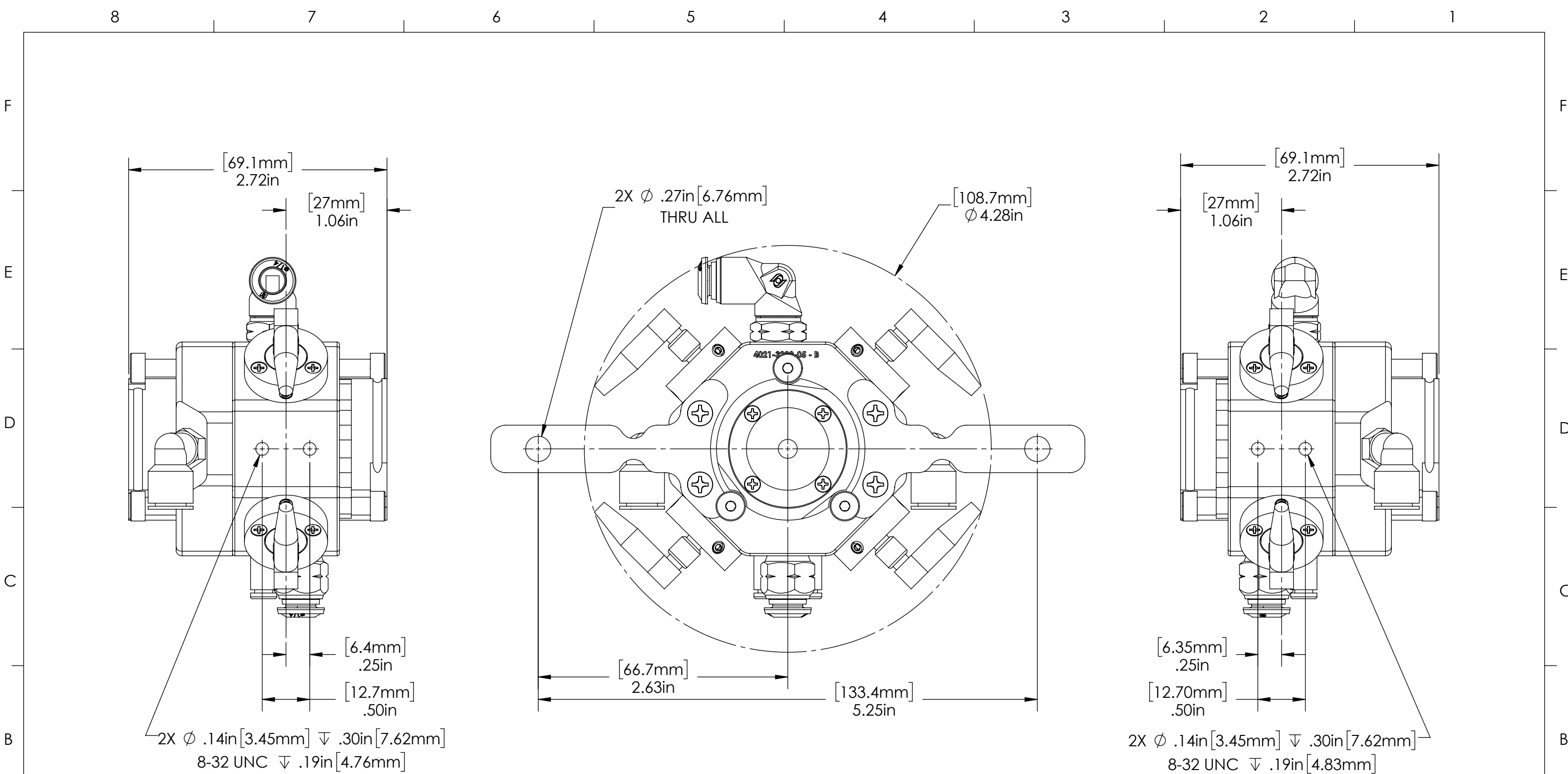

GENERAL FINISH NOTE DE-BURR AND BREAK ALL SHARP EDGES BEFORE FINISH AND/OR SHIPPING	UNLESS OTHERWISE SPECIFIED:	NAME	DATE	 LASERLINC, INC. PHONE: 888-707-4892 INFO@LASERLINC.COM WWW.LASERLINC.COM	
	DIMENSIONS ARE IN INCHES	DRAWN BY:	DRP		4/3/2013
	TOLERANCES: ANGLES $\pm .25$ TWO PLACE DECIMAL ± 0.010 THREE PLACE DECIMAL ± 0.005 FOUR PLACE DECIMAL ± 0.0005 UNMARKED FILLETS/CHAMFER .06 DE-BURR ALL PARTS				
PROPRIETARY AND CONFIDENTIAL	INTERPRET GEOMETRIC TOLERANCING PER: ASME Y14.5	63 RA SURFACE FINISH ALL FEATURES MUST MEET SPECIFICATION AFTER PLATING BEFORE POWDER-COAT IF PLATED OR POWDER-COATED SEE FINISH		TITLE: 4021-0002-00 R4-8SC PIVOTING TRANSDUCER ASSEMBLY OVERALLS	
THE INFORMATION CONTAINED IN THIS DRAWING IS THE SOLE PROPERTY OF LASERLINC, INC. ANY REPRODUCTION IN PART OR AS A WHOLE WITHOUT THE WRITTEN PERMISSION OF LASERLINC, INC. IS PROHIBITED.	MATERIAL			SIZE B DWG. NO. 4021-0002-00 REV B	
	FINISH NONE			SCALE: 1:1 SHEET 2 OF 3	
	DO NOT SCALE DRAWING				

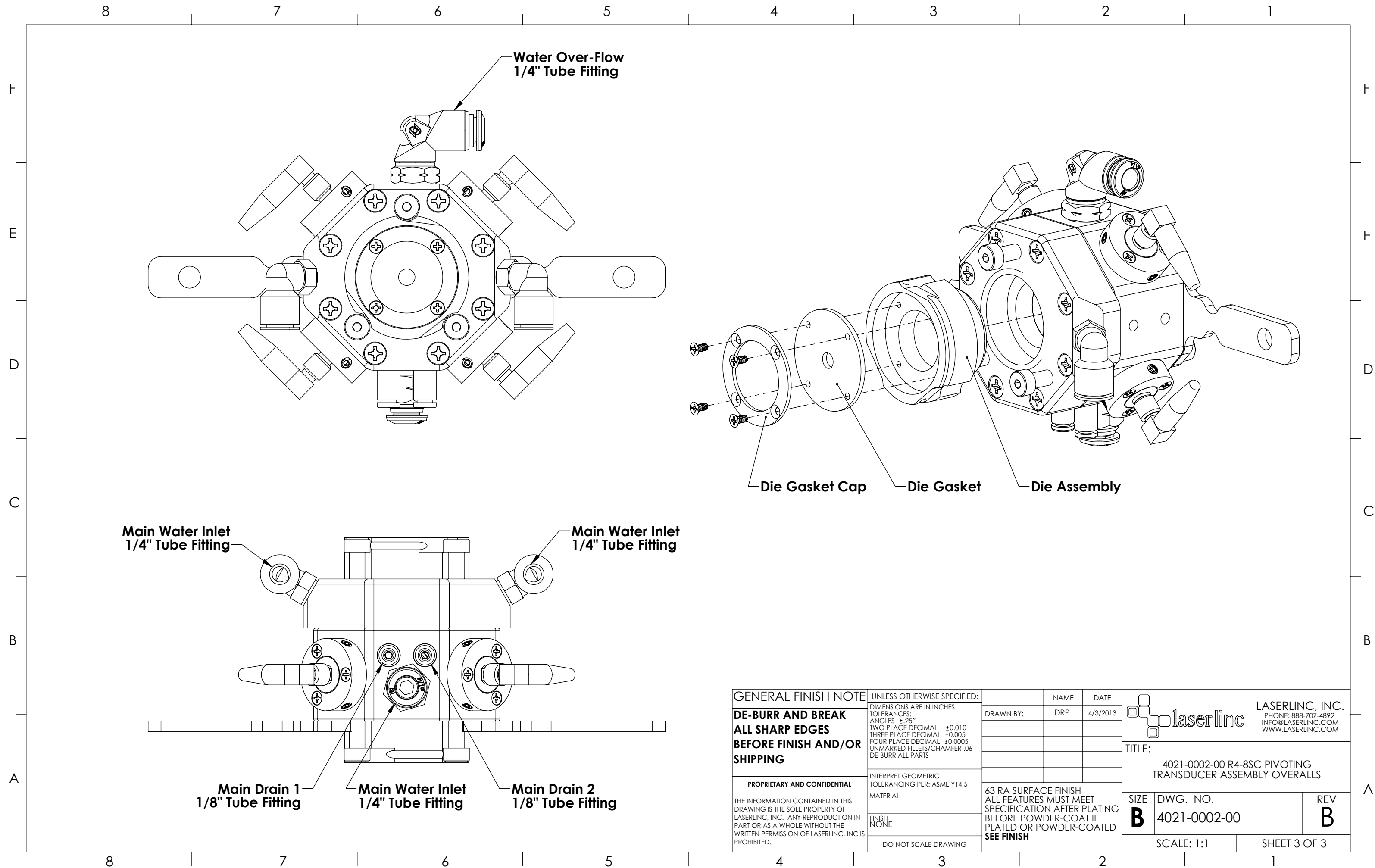

GENERAL FINISH NOTE DE-BURR AND BREAK ALL SHARP EDGES BEFORE FINISH AND/OR SHIPPING	UNLESS OTHERWISE SPECIFIED: DIMENSIONS ARE IN INCHES TOLERANCES: ANGLES ±.25 TWO PLACE DECIMAL ±0.010 THREE PLACE DECIMAL ±0.005 FOUR PLACE DECIMAL ±0.0005 UNMARKED FILLETS/CHAMFER .06 DE-BURR ALL PARTS	NAME DATE	 LASERLINC, INC. PHONE: 888-707-4892 INFO@LASERLINC.COM WWW.LASERLINC.COM			
	PROPRIETARY AND CONFIDENTIAL	INTERPRET GEOMETRIC TOLERANCING PER: ASME Y14.5		DRAWN BY: DRP DATE: 4/3/2013		
THE INFORMATION CONTAINED IN THIS DRAWING IS THE SOLE PROPERTY OF LASERLINC, INC. ANY REPRODUCTION IN PART OR AS A WHOLE WITHOUT THE WRITTEN PERMISSION OF LASERLINC, INC. IS PROHIBITED.	MATERIAL	63 RA SURFACE FINISH ALL FEATURES MUST MEET SPECIFICATION AFTER PLATING BEFORE POWDER-COAT IF PLATED OR POWDER-COATED SEE FINISH	TITLE: 4021-0002-00 R4-8SC PIVOTING TRANSDUCER ASSEMBLY OVERALLS			
	FINISH NONE	DO NOT SCALE DRAWING	<table border="1"> <tr> <td>SIZE B</td> <td>DWG. NO. 4021-0002-00</td> <td>REV B</td> </tr> </table>	SIZE B	DWG. NO. 4021-0002-00	REV B
SIZE B	DWG. NO. 4021-0002-00	REV B				
			SCALE: 1:1 SHEET 3 OF 3			