

REVISIONS

ECO	REV.	DESCRIPTION	DATE	APPROVED
	A	CHECKED-IN	8/8/2023	CJM
	B	CHANGED ROLLER BUILD-UP	5/22/2024	CJM

UG412 6IN X 6IN - 8IN X 8IN TANK SMALL PLASTIC ROLLER GUIDE ARM ASSEMBLY

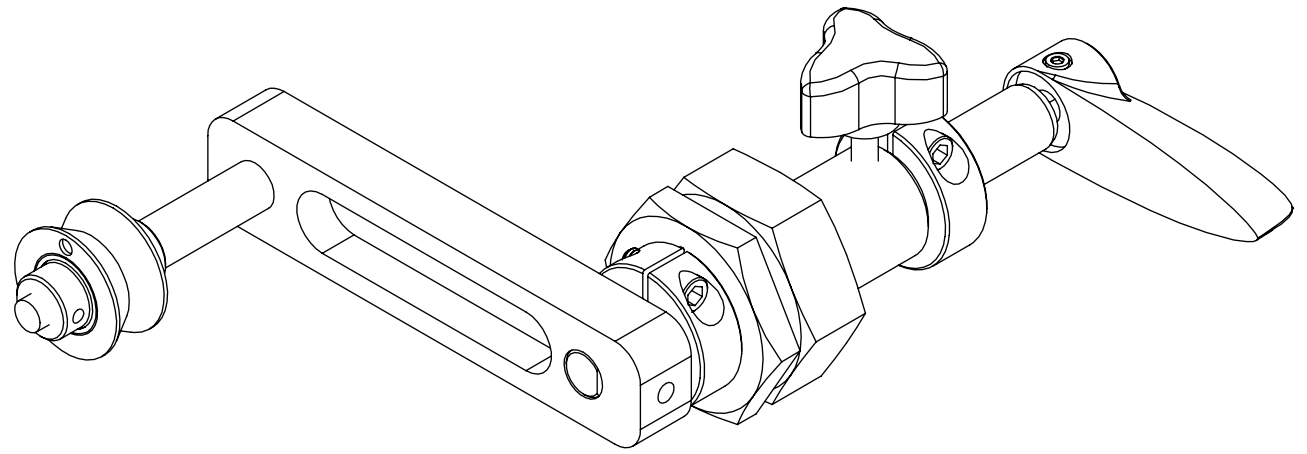

INDEX

- (1) COVER PAGE
- (2) BILL OF MATERIALS
- (3) DELRIN ARM ASSEMBLY
- (4) FULL ARM ASSEMBLY
- (5) DIMENSIONS

GENERAL FINISH NOTE		UNLESS OTHERWISE SPECIFIED:		NAME	DATE	 LASERLINC, INC. PHONE: 937-318-2440 INFO@LASERLINC.COM WWW.LASERLINC.COM
DE-BURR AND BREAK ALL SHARP EDGES BEFORE FINISH AND/OR SHIPPING		DIMENSIONS ARE IN INCHES TOLERANCES: ANGLES ±.25° TWO PLACE DECIMAL ±0.010 THREE PLACE DECIMAL ±0.005 FOUR PLACE DECIMAL ±0.0005 UNMARKED FILLETS/CHAMFER .06 DE-BURR ALL PARTS		DRAWN BY:	CJM	
PROPRIETARY AND CONFIDENTIAL		INTERPRET GEOMETRIC TOLERANCING PER: ASME Y14.5				
THE INFORMATION CONTAINED IN THIS DRAWING IS THE SOLE PROPERTY OF LASERLINC, INC. ANY REPRODUCTION IN PART OR AS A WHOLE WITHOUT THE WRITTEN PERMISSION OF LASERLINC, INC. IS PROHIBITED.		MATERIAL		63 RA SURFACE FINISH ALL FEATURES MUST MEET SPECIFICATION AFTER PLATING BEFORE POWDER-COAT IF PLATED OR POWDER-COATED SEE FINISH		TITLE: UG412 6IN X 6IN - 8IN X 8IN TANK SMALL PLASTIC ROLLER GUIDE ARM ASSEMBLY
		FINISH				SIZE B DWG. NO. 0412-0005-61 REV A
		DO NOT SCALE DRAWING				SCALE: 3:4 SHEET 1 OF 4

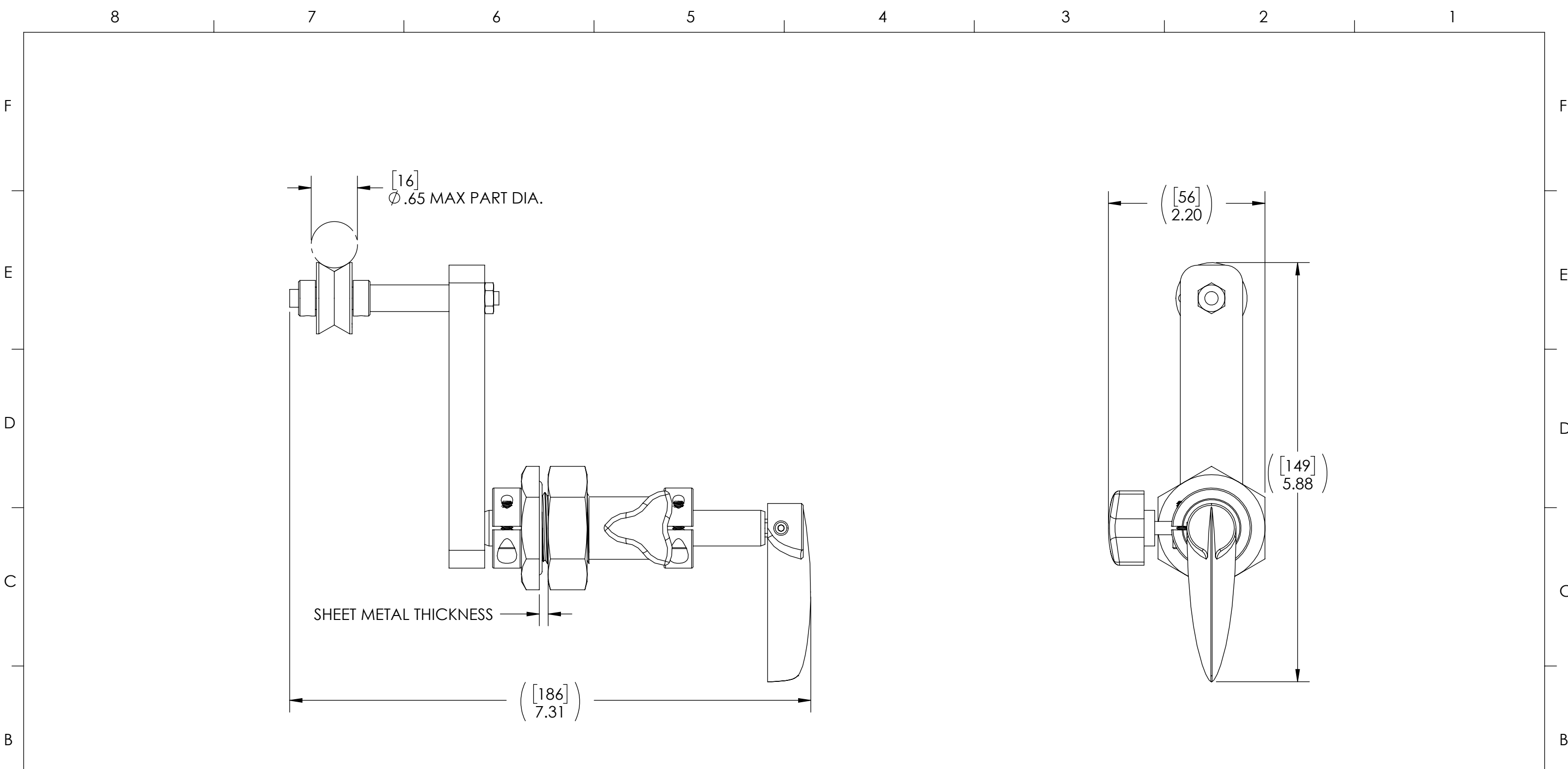

SHEET METAL THICKNESS

[16]
 \varnothing .65 MAX PART DIA.

[186]
 7.31

[56]
 2.20

[149]
 5.88

GENERAL FINISH NOTE		UNLESS OTHERWISE SPECIFIED:		NAME	DATE
DE-BURR AND BREAK ALL SHARP EDGES BEFORE FINISH AND/OR SHIPPING		DIMENSIONS ARE IN INCHES		DRAWN BY:	CJM
		TOLERANCES:			08/07/2023
PROPRIETARY AND CONFIDENTIAL		ANGLES \pm .25°			
		TWO PLACE DECIMAL \pm 0.010			
THE INFORMATION CONTAINED IN THIS DRAWING IS THE SOLE PROPERTY OF LASERLINC, INC. ANY REPRODUCTION IN PART OR AS A WHOLE WITHOUT THE WRITTEN PERMISSION OF LASERLINC, INC. IS PROHIBITED.		THREE PLACE DECIMAL \pm 0.005			
		FOUR PLACE DECIMAL \pm 0.0005			
		INTERPRET GEOMETRIC TOLERANCING PER: ASME Y14.5			
		MATERIAL			
		FINISH			
		DO NOT SCALE DRAWING			
		63 RA SURFACE FINISH ALL FEATURES MUST MEET SPECIFICATION AFTER PLATING BEFORE POWDER-COAT IF PLATED OR POWDER-COATED SEE FINISH			
		LASERLINC, INC. PHONE: 937-318-2440 INFO@LASERLINC.COM WWW.LASERLINC.COM			
		TITLE: UG412 6IN X 6IN - 8IN X 8IN TANK SMALL PLASTIC ROLLER GUIDE ARM ASSEMBLY			
SIZE	DWG. NO.	REV			
B	0412-0005-61	A			
SCALE: 3:4		SHEET 4 OF 4			