

8

7

6

5

4

3

2

1

REVISIONS

ECO	REV.	DESCRIPTION	DATE	APPROVED
	A	CHECKED-IN	5/21/2024	CJM

F

F

E

E

D

D

C

C

B

B

A

A

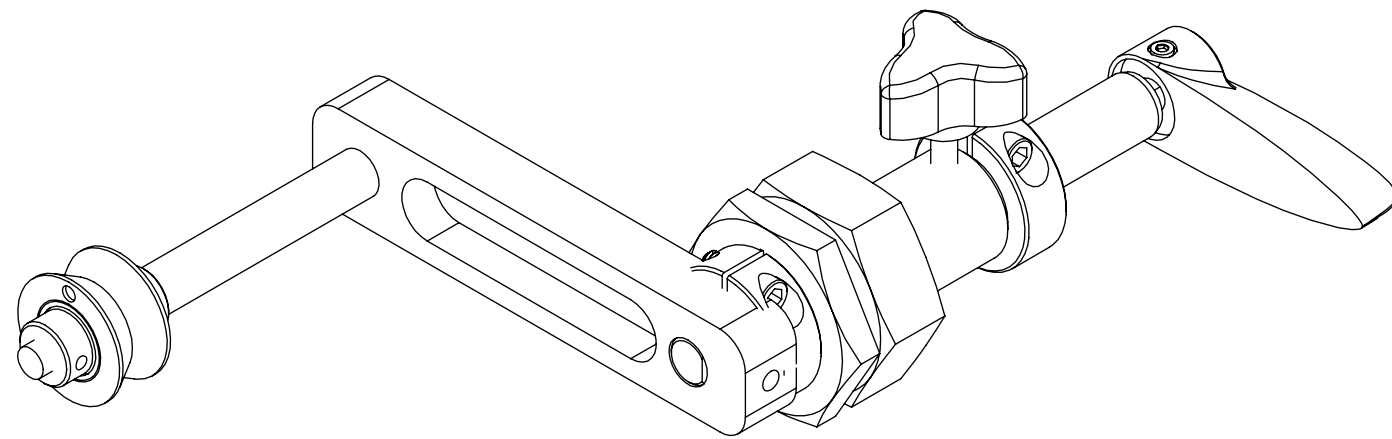

# UG412 8IN X 8IN - 10IN X 10IN TANK SMALL PLASTIC ROLLER GUIDE ARM ASSEMBLY

### INDEX

- (1) COVER PAGE
- (2) BILL OF MATERIALS
- (3) DELRIN ARM ASSEMBLY
- (4) FULL ARM ASSEMBLY
- (5) DIMENSIONS

<b>GENERAL FINISH NOTE</b>		UNLESS OTHERWISE SPECIFIED:		NAME	DATE	 <b>LASERLINC, INC.</b> PHONE: 937-318-2440 INFO@LASERLINC.COM WWW.LASERLINC.COM
<b>DE-BURR AND BREAK ALL SHARP EDGES BEFORE FINISH AND/OR SHIPPING</b>		DIMENSIONS ARE IN INCHES TOLERANCES: ANGLES ±.25° TWO PLACE DECIMAL ±0.010 THREE PLACE DECIMAL ±0.005 FOUR PLACE DECIMAL ±0.0005 UNMARKED FILLETS/CHAMFER .06 DE-BURR ALL PARTS		DRAWN BY:	CJM	
<b>PROPRIETARY AND CONFIDENTIAL</b>		INTERPRET GEOMETRIC TOLERANCING PER: ASME Y14.5				
THE INFORMATION CONTAINED IN THIS DRAWING IS THE SOLE PROPERTY OF LASERLINC, INC. ANY REPRODUCTION IN PART OR AS A WHOLE WITHOUT THE WRITTEN PERMISSION OF LASERLINC, INC. IS PROHIBITED.		MATERIAL		63 RA SURFACE FINISH ALL FEATURES MUST MEET SPECIFICATION AFTER PLATING BEFORE POWDER-COAT IF PLATED OR POWDER-COATED <b>SEE FINISH</b>		TITLE: UG412 8IN X 8IN - 10IN X 10IN TANK SMALL PLASTIC ROLLER GUIDE ARM ASSEMBLY
		FINISH				SIZE <b>B</b>
		DO NOT SCALE DRAWING				DWG. NO. 0412-0008-61
						REV <b>A</b>
						SCALE: 3:4
						SHEET 1 OF 4

8

7

6

5

4

3

2

1

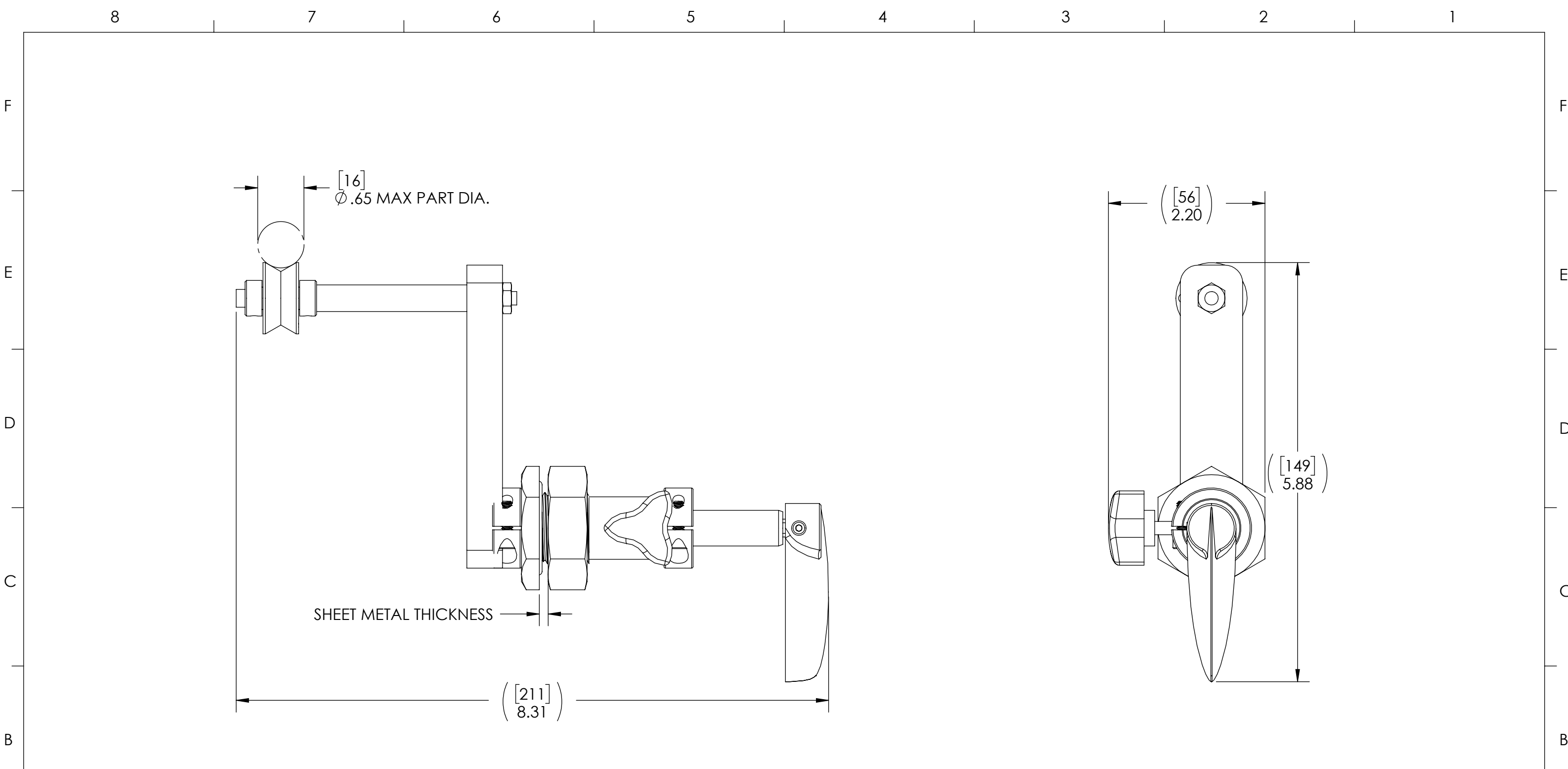

<b>GENERAL FINISH NOTE</b>		UNLESS OTHERWISE SPECIFIED:		NAME	DATE
<b>DE-BURR AND BREAK ALL SHARP EDGES BEFORE FINISH AND/OR SHIPPING</b>		DIMENSIONS ARE IN INCHES TOLERANCES: ANGLES ±.25° TWO PLACE DECIMAL ±0.010 THREE PLACE DECIMAL ±0.005 FOUR PLACE DECIMAL ±0.0005 UNMARKED FILLETS/CHAMFER .06 DE-BURR ALL PARTS		DRAWN BY:	CJM 05/21/2024
<b>PROPRIETARY AND CONFIDENTIAL</b>		INTERPRET GEOMETRIC TOLERANCING PER: ASME Y14.5			
THE INFORMATION CONTAINED IN THIS DRAWING IS THE SOLE PROPERTY OF LASERLINC, INC. ANY REPRODUCTION IN PART OR AS A WHOLE WITHOUT THE WRITTEN PERMISSION OF LASERLINC, INC. IS PROHIBITED.		MATERIAL		63 RA SURFACE FINISH ALL FEATURES MUST MEET SPECIFICATION AFTER PLATING BEFORE POWDER-COAT IF PLATED OR POWDER-COATED <b>SEE FINISH</b>	
		FINISH			
		DO NOT SCALE DRAWING		TITLE: UG412 8IN X 8IN - 10IN X 10IN TANK SMALL PLASTIC ROLLER GUIDE ARM ASSEMBLY	
				SIZE <b>B</b>	DWG. NO. 0412-0008-61
				REV <b>A</b>	
				SCALE: 3:4	SHEET 4 OF 4

