

REVISIONS

ZONE	REV.	DESCRIPTION	DATE	APPROVED
	E	CHECK-IN	5/6/2021	EMM

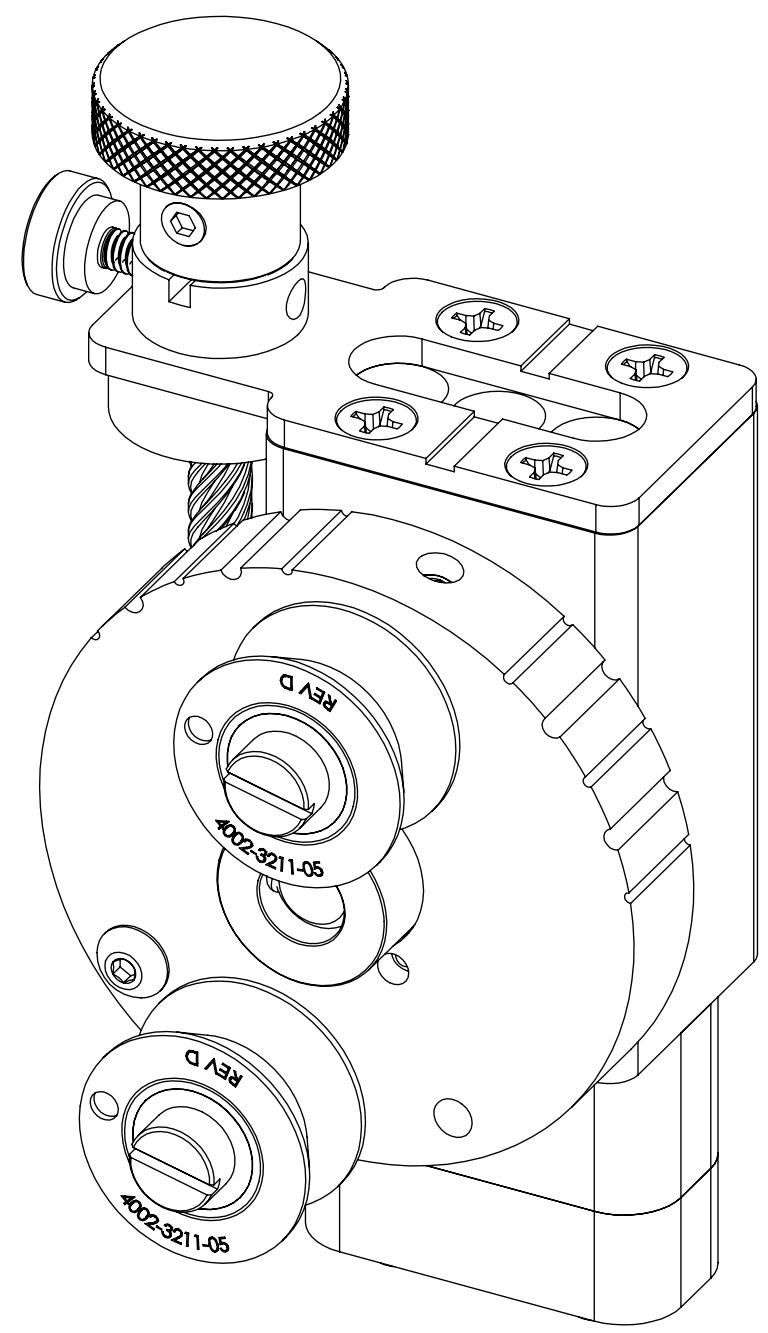

# ULTRA GAUGE 412 LEFT TENSION ROLLER GUIDE GEARED ASSEMBLY OVERALLS

## INDEX

- (1) COVER PAGE
- (2) FIXTURE DIMENSIONS
- (3) MOUNTED DIMENSIONS

GENERAL FINISH NOTE DE-BURR AND BREAK ALL SHARP EDGES BEFORE FINISH AND/OR SHIPPING	UNLESS OTHERWISE SPECIFIED: DIMENSIONS ARE IN INCHES TOLERANCES: ANGLES ±.25 TWO PLACE DECIMAL ±0.010 THREE PLACE DECIMAL ±0.005 FOUR PLACE DECIMAL ±0.0005 UNMARKED FILLETS/CHAMFER .06 DE-BURR ALL PARTS	DRAWN BY:	NAME	DATE	 <b>LASERLINC, INC.</b> PHONE: 888-707-4892 INFO@LASERLINC.COM WWW.LASERLINC.COM
	INTERPRET GEOMETRIC TOLERANCING PER: ASME Y14.5		EMM	5/6/2021	
PROPRIETARY AND CONFIDENTIAL	MATERIAL	63 RA SURFACE FINISH ALL FEATURES MUST MEET SPECIFICATION AFTER PLATING BEFORE POWDER-COAT IF PLATED OR POWDER-COATED SEE FINISH			TITLE:
THE INFORMATION CONTAINED IN THIS DRAWING IS THE SOLE PROPERTY OF LASERLINC, INC. ANY REPRODUCTION IN PART OR AS A WHOLE WITHOUT THE WRITTEN PERMISSION OF LASERLINC, INC. IS PROHIBITED.	FINISH				SIZE
	DO NOT SCALE DRAWING				0412-0002-61 UG412 LEFT TENSION ROLLER GUIDE GEARED ASSEMBLY OVERALLS <b>B</b> 0412-0002-61 <b>E</b> SCALE: 4:3 SHEET 1 OF 3

8 7 6 5 4 3 2 1

F

E

D

C

B

A

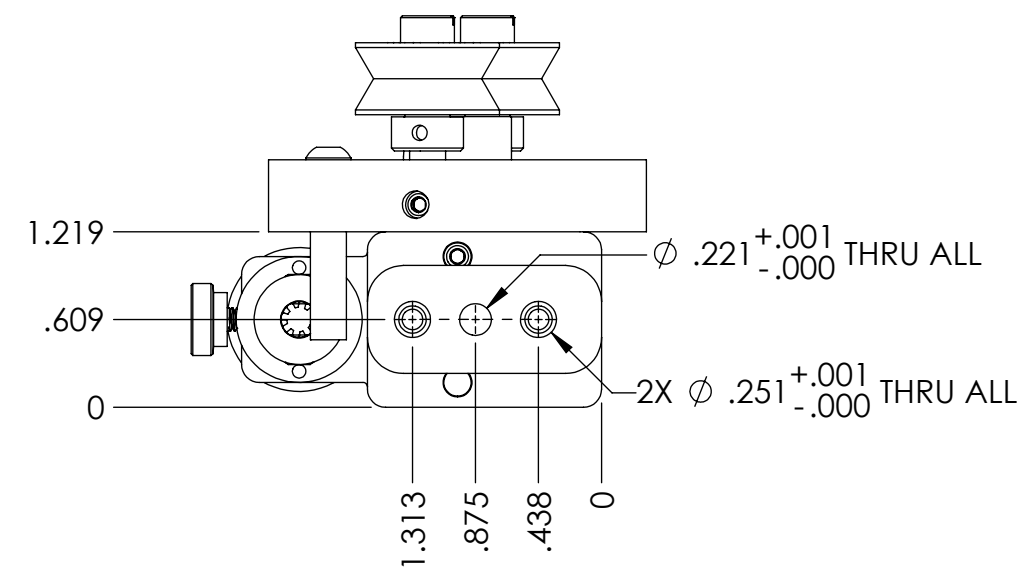
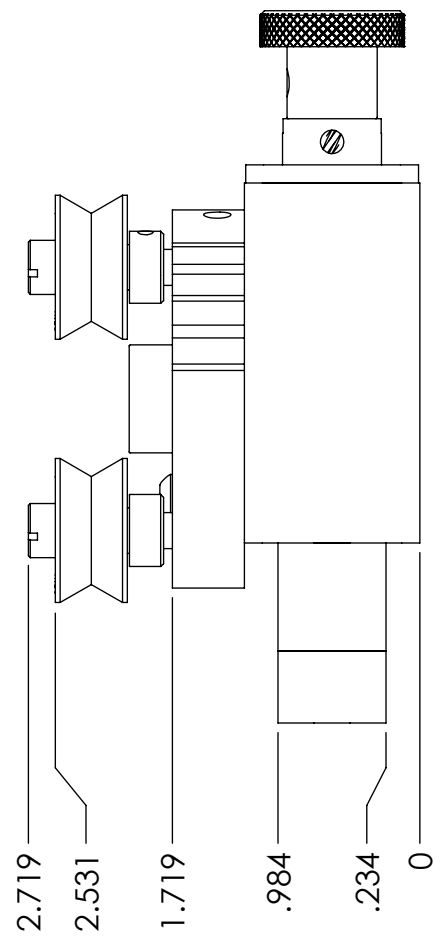
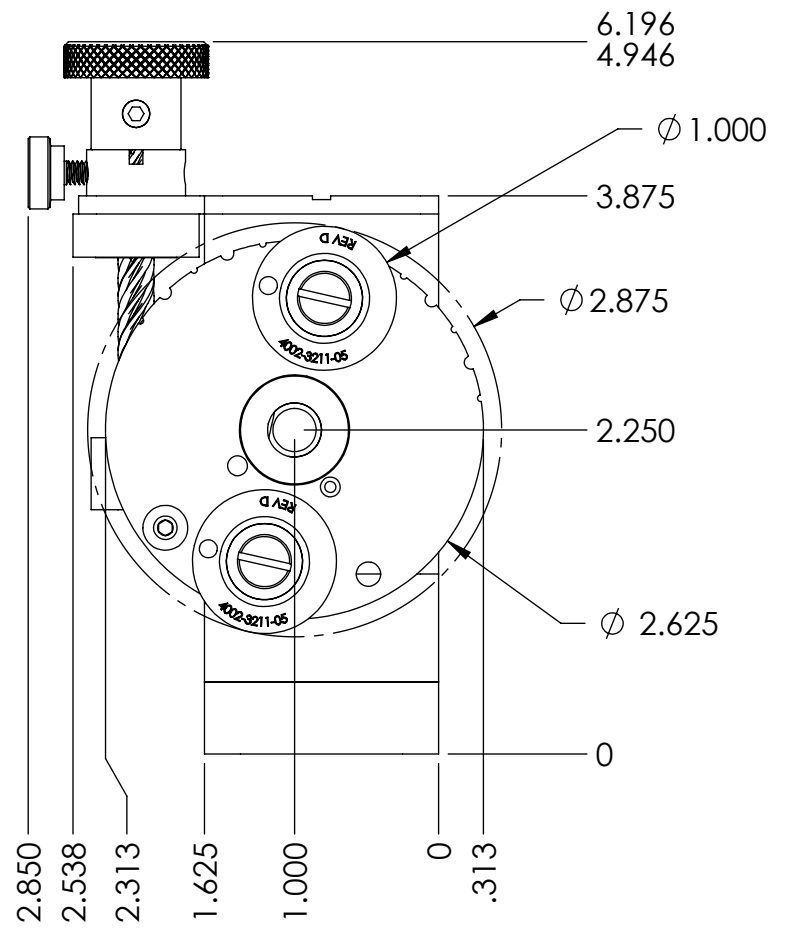

GENERAL FINISH NOTE DE-BURR AND BREAK ALL SHARP EDGES BEFORE FINISH AND/OR SHIPPING	UNLESS OTHERWISE SPECIFIED: DIMENSIONS ARE IN INCHES TOLERANCES: ANGLES ±.25 TWO PLACE DECIMAL ±0.010 THREE PLACE DECIMAL ±0.005 FOUR PLACE DECIMAL ±0.0005 UNMARKED FILLETS/CHAMFER .06 DE-BURR ALL PARTS	NAME	DATE	 <b>LASERLINC, INC.</b> PHONE: 888-707-4892 INFO@LASERLINC.COM WWW.LASERLINC.COM
	INTERPRET GEOMETRIC TOLERANCING PER: ASME Y14.5	DRAWN BY:	EMM	
PROPRIETARY AND CONFIDENTIAL	MATERIAL	63 RA SURFACE FINISH ALL FEATURES MUST MEET SPECIFICATION AFTER PLATING BEFORE POWDER-COAT IF PLATED OR POWDER-COATED SEE FINISH		TITLE: 0412-0002-61 UG412 LEFT TENSION ROLLER GUIDE GEARED ASSEMBLY OVERALLS
THE INFORMATION CONTAINED IN THIS DRAWING IS THE SOLE PROPERTY OF LASERLINC, INC. ANY REPRODUCTION IN PART OR AS A WHOLE WITHOUT THE WRITTEN PERMISSION OF LASERLINC, INC. IS PROHIBITED.	FINISH	SIZE <b>B</b>	DWG. NO. 0412-0002-61	REV <b>E</b>
DO NOT SCALE DRAWING		SCALE: 3:4		SHEET 2 OF 3

8 7 6 5 4 3 2 1

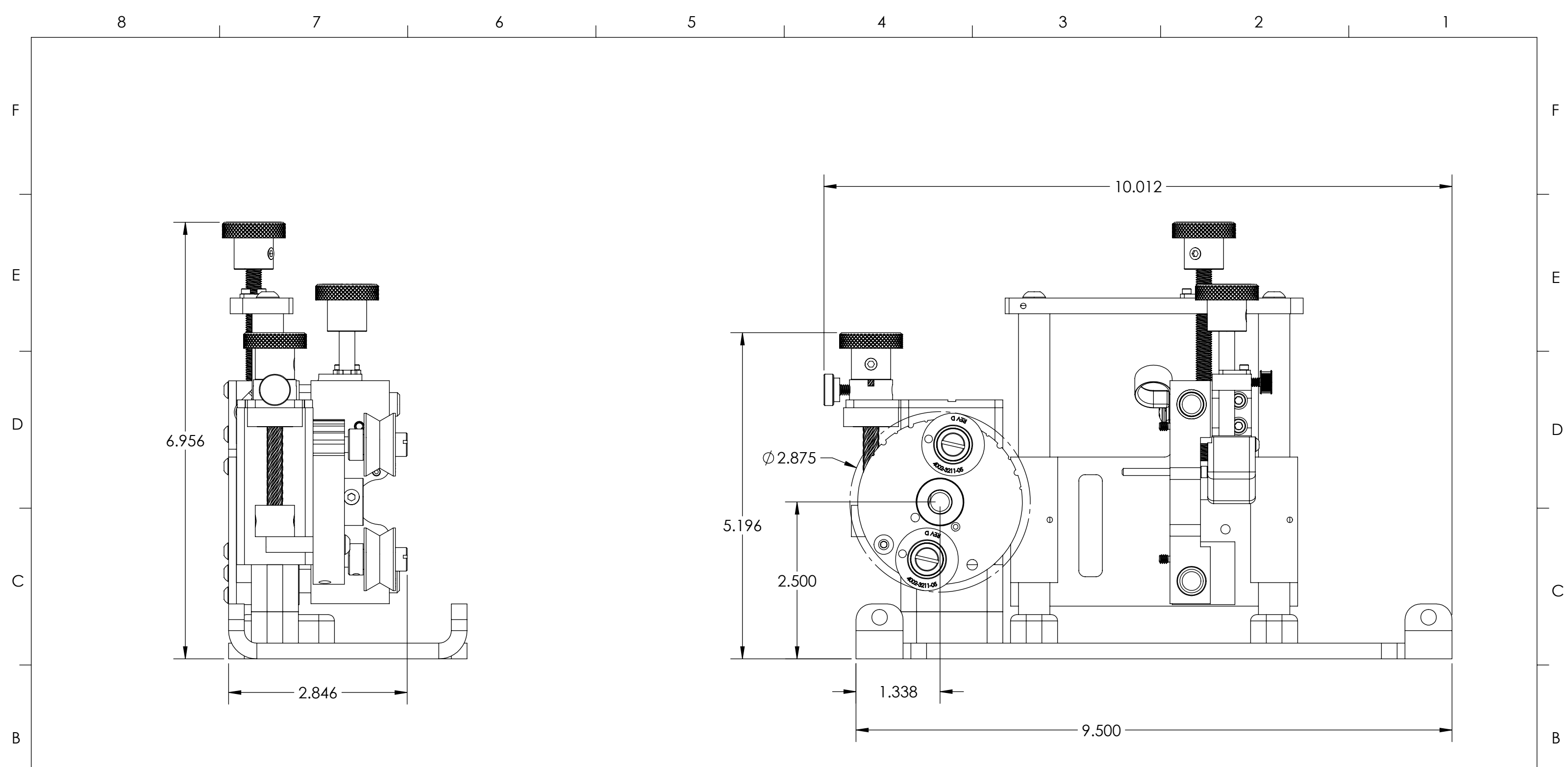

<b>GENERAL FINISH NOTE</b> DE-BURR AND BREAK ALL SHARP EDGES BEFORE FINISH AND/OR SHIPPING	UNLESS OTHERWISE SPECIFIED: DIMENSIONS ARE IN INCHES TOLERANCES: ANGLES ±.25 TWO PLACE DECIMAL ±0.010 THREE PLACE DECIMAL ±0.005 FOUR PLACE DECIMAL ±0.0005 UNMARKED FILLETS/CHAMFER .06 DE-BURR ALL PARTS	NAME EMM DATE 5/6/2021	 <b>LASERLINC, INC.</b> PHONE: 888-707-4892 INFO@LASERLINC.COM WWW.LASERLINC.COM		
	PROPRIETARY AND CONFIDENTIAL THE INFORMATION CONTAINED IN THIS DRAWING IS THE SOLE PROPERTY OF LASERLINC, INC. ANY REPRODUCTION IN PART OR AS A WHOLE WITHOUT THE WRITTEN PERMISSION OF LASERLINC, INC. IS PROHIBITED.	INTERPRET GEOMETRIC TOLERANCING PER: ASME Y14.5 MATERIAL FINISH DO NOT SCALE DRAWING		DRAWN BY: TITLE: 0412-0002-61 UG412 LEFT TENSION ROLLER GUIDE GEARED ASSEMBLY OVERALLS	
		63 RA SURFACE FINISH ALL FEATURES MUST MEET SPECIFICATION AFTER PLATING BEFORE POWDER-COAT IF PLATED OR POWDER-COATED SEE FINISH	SIZE <b>B</b>	DWG. NO. 0412-0002-61	REV <b>E</b>
		SCALE: 2:3	SHEET 3 OF 3		