

8 7 6 5 4 3 2 1

F

E

D

C

B

A

| REVISIONS | | | | |
|-----------|------|---|------------|----------|
| ZONE | REV. | DESCRIPTION | DATE | APPROVED |
| | A | Check-in | 6/6/2013 | DRP |
| | B | Changed 8-32 Mounting Holes to 1/4-20. | 9/27/2013 | DRP |
| | C | MATCHING MODEL REV | 9/14/2018 | RJN |
| | D | MATCHING MODEL REV | 9/19/2018 | RJN |
| | E | MATCHING MODEL REV | 11/20/2018 | MAM |
| | F | REPLACED XY ADJUSTMENT & TRANSDUCER ASSEMBLIES- NEW VERSION | 5/7/2019 | JWB |

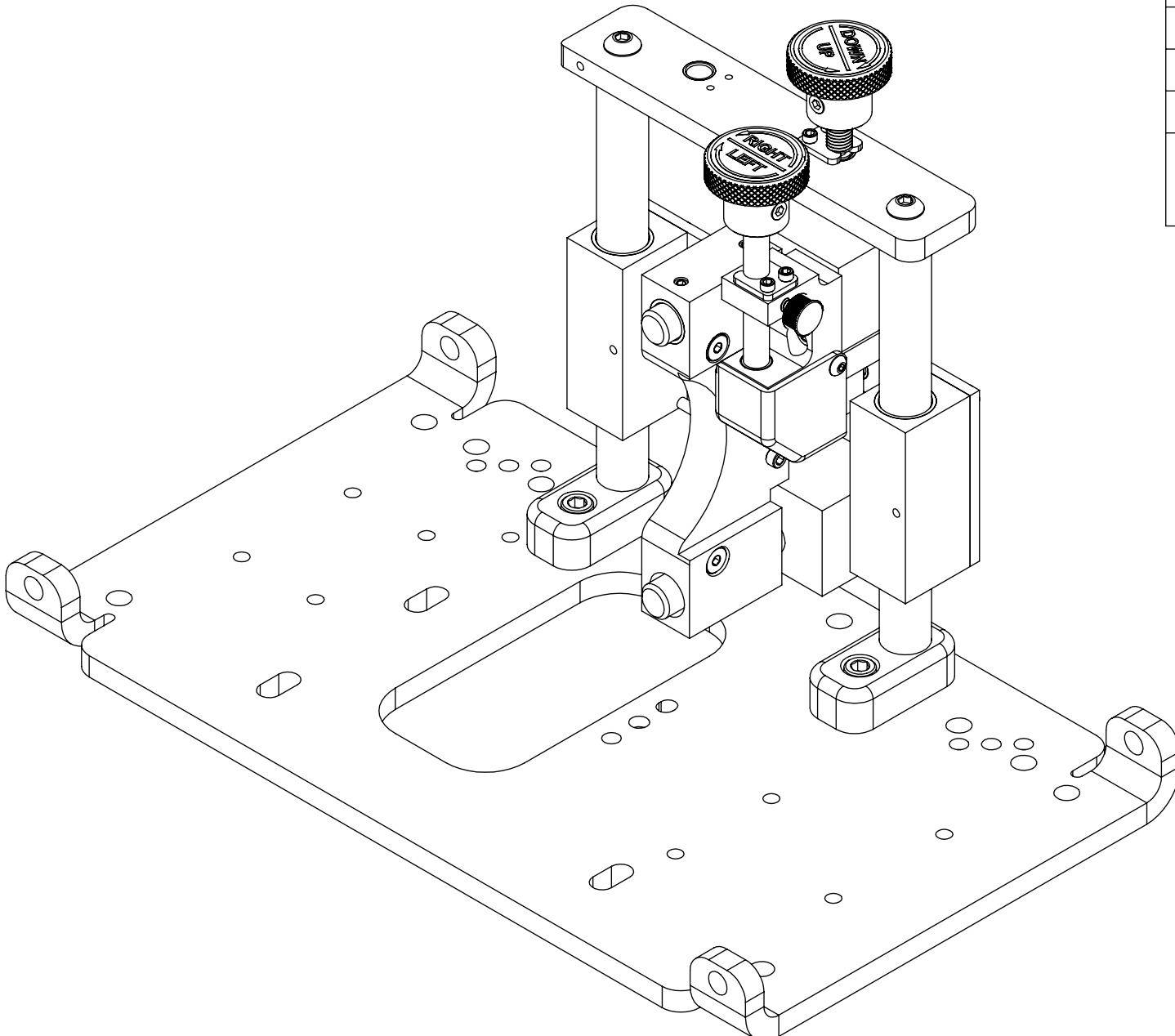

ULTRA GUAGE 430 GEARED IN-TANK MOUNTING ASSEMBLY OVERALLS

INDEX

- (1) COVER PAGE
- (2) GENREAL DIMENSIONS
- (3) MOUNTING DIMENSIONS

| | | | | |
|--|--|---|--------------------------|--|
| GENERAL FINISH NOTE DE-BURR AND BREAK ALL SHARP EDGES BEFORE FINISH AND/OR SHIPPING | UNLESS OTHERWISE SPECIFIED: DIMENSIONS ARE IN INCHES TOLERANCES: ANGLES ±.25 TWO PLACE DECIMAL ±0.010 THREE PLACE DECIMAL ±0.005 FOUR PLACE DECIMAL ±0.0005 UNMARKED FILLETS/CHAMFER .06 DE-BURR ALL PARTS | NAME | DATE |  LASERLINC, INC. PHONE: 888-707-4892 INFO@LASERLINC.COM WWW.LASERLINC.COM |
| | INTERPRET GEOMETRIC TOLERANCING PER: ASME Y14.5 | DRAWN BY: | EMM | |
| PROPRIETARY AND CONFIDENTIAL | MATERIAL LL | 63 RA SURFACE FINISH ALL FEATURES MUST MEET SPECIFICATION AFTER PLATING BEFORE POWDER-COAT IF PLATED OR POWDER-COATED SEE FINISH | | TITLE: 0430-0000-28 UG430 GEARED IN-TANK MOUNTING ASSEMBLY OVERALLS |
| THE INFORMATION CONTAINED IN THIS DRAWING IS THE SOLE PROPERTY OF LASERLINC, INC. ANY REPRODUCTION IN PART OR AS A WHOLE WITHOUT THE WRITTEN PERMISSION OF LASERLINC, INC. IS PROHIBITED. | FINISH | SIZE B | DWG. NO. 0430-0000-28 | REV F |
| | DO NOT SCALE DRAWING | SCALE: 2:3 | | SHEET 1 OF 3 |

8 7 6 5 4 3 2 1

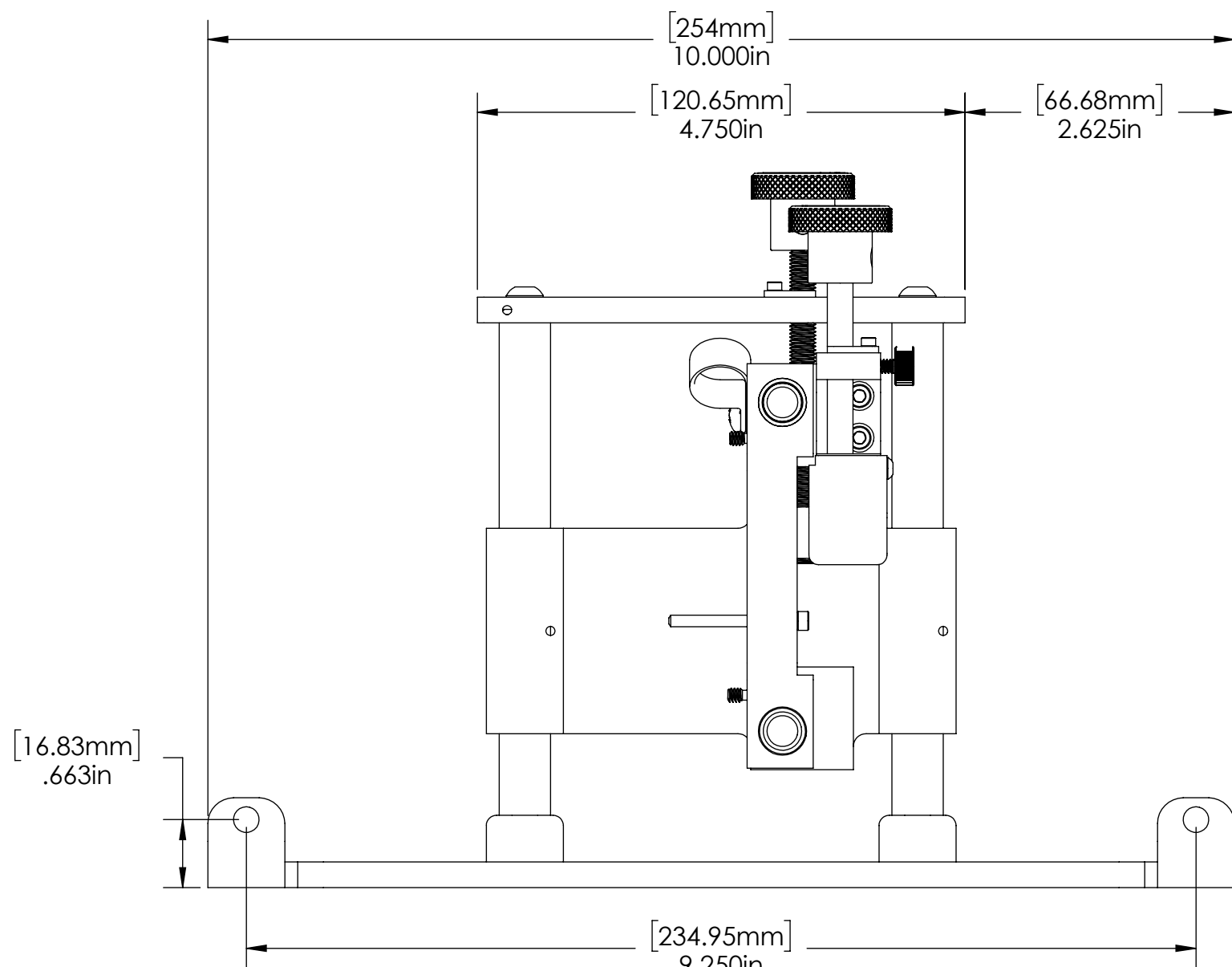
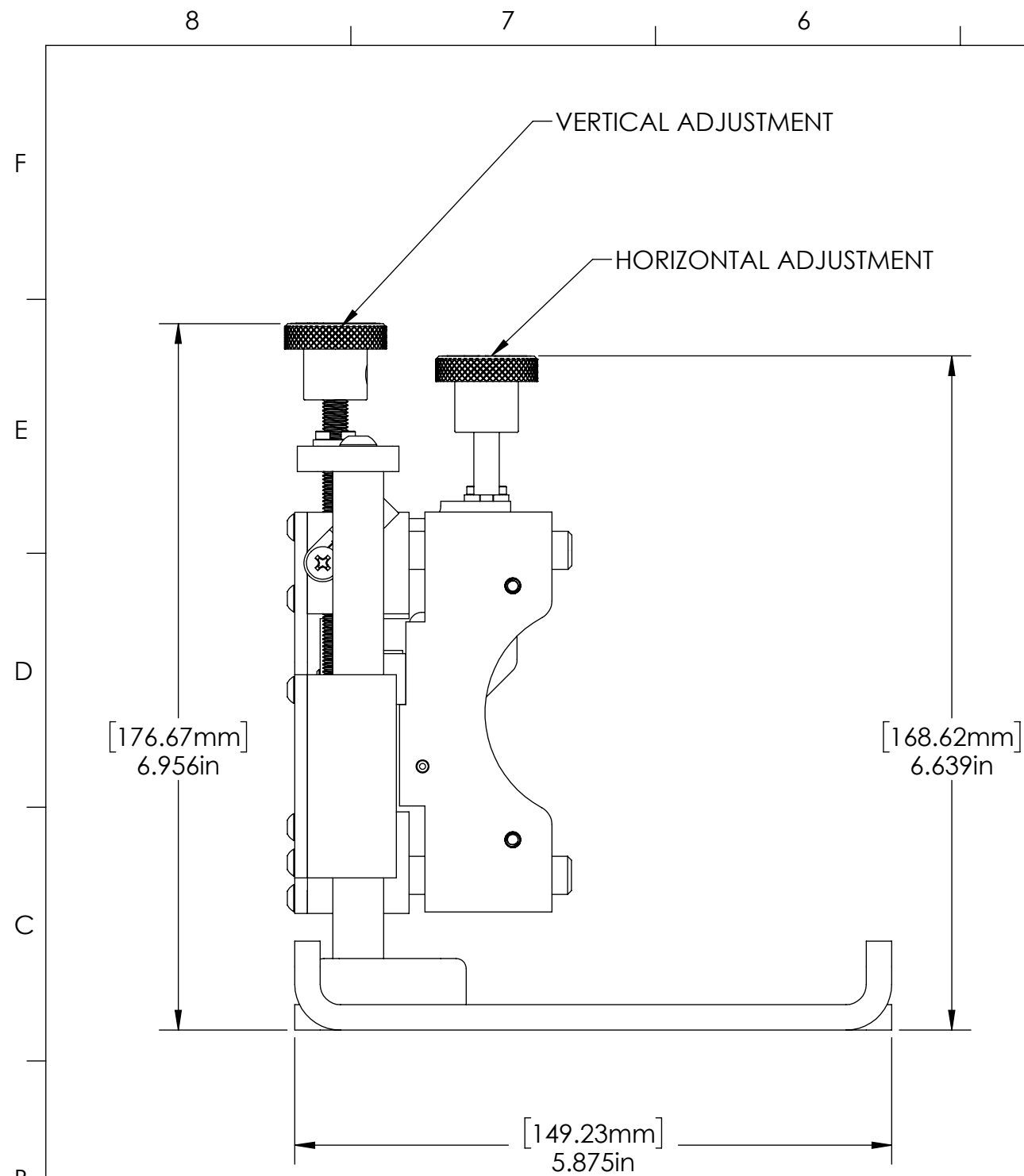

| | | | | |
|--|---|---|------------------|--|
| GENERAL FINISH NOTE DE-BURR AND BREAK ALL SHARP EDGES BEFORE FINISH AND/OR SHIPPING | UNLESS OTHERWISE SPECIFIED: DIMENSIONS ARE IN INCHES TOLERANCES: ANGLES ±.25° TWO PLACE DECIMAL ±0.010 THREE PLACE DECIMAL ±0.005 FOUR PLACE DECIMAL ±0.0005 UNMARKED FILLETS/CHAMFER .06 DE-BURR ALL PARTS | NAME EMM | DATE 5/7/2021 |  LaserLinc, Inc. Phone: 888-707-4892 Info@laserlinc.com www.laserlinc.com |
| | PROPRIETARY AND CONFIDENTIAL | INTERPRET GEOMETRIC TOLERANCING PER: ASME Y14.5 | DRAWN BY: | |
| THE INFORMATION CONTAINED IN THIS DRAWING IS THE SOLE PROPERTY OF LASERLINC, INC. ANY REPRODUCTION IN PART OR AS A WHOLE WITHOUT THE WRITTEN PERMISSION OF LASERLINC, INC. IS PROHIBITED. | MATERIAL LL | 63 RA SURFACE FINISH ALL FEATURES MUST MEET SPECIFICATION AFTER PLATING BEFORE POWDER-COAT IF PLATED OR POWDER-COATED SEE FINISH | | SIZE B |
| | FINISH | | | DWG. NO. 0430-0000-28 |
| | DO NOT SCALE DRAWING | | | REV F |
| | | | | SCALE: 2:3 |
| | | | | SHEET 2 OF 3 |

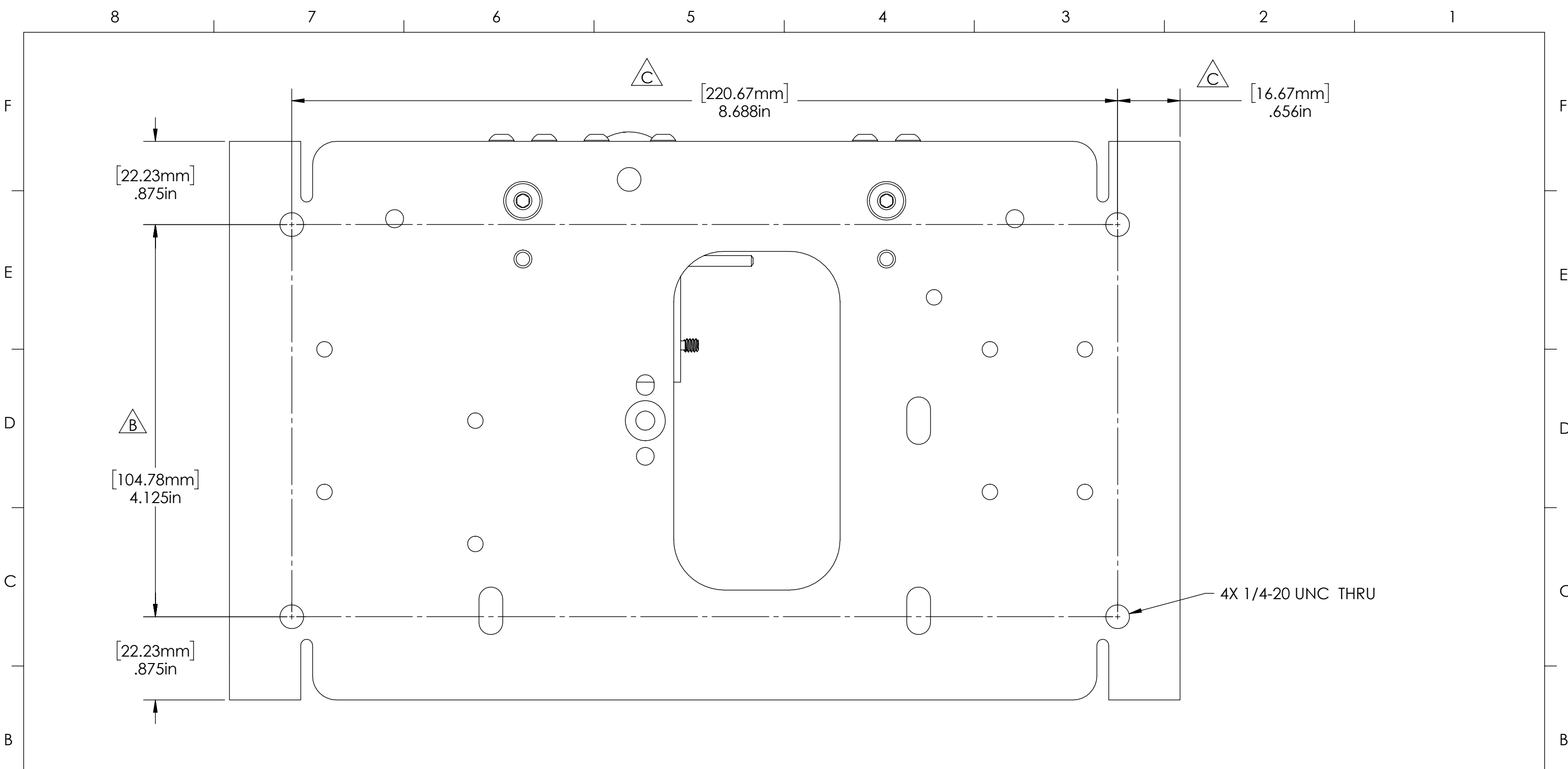

| | | | | | | |
|---|--|---|---|---|--------------------------|-----------------|
| GENERAL FINISH NOTE DE-BURR AND BREAK ALL SHARP EDGES BEFORE FINISH AND/OR SHIPPING | UNLESS OTHERWISE SPECIFIED: DIMENSIONS ARE IN INCHES TOLERANCES: ANGLES ±.25 TWO PLACE DECIMAL ±0.010 THREE PLACE DECIMAL ±0.005 FOUR PLACE DECIMAL ±0.0005 UNMARKED FILLETS/CHAMFER .06 DE-BURR ALL PARTS | NAME DATE | LaserLinc, Inc. Phone: 888-707-4892 info@laserlinc.com www.laserlinc.com | | | |
| | PROPRIETARY AND CONFIDENTIAL | INTERPRET GEOMETRIC TOLERANCING PER: ASME Y14.5 | DRAWN BY: EMM DATE: 5/7/2021 | TITLE: 0430-0000-28 UG430 Geared In-Tank Mounting Assembly Overalls | | |
| THE INFORMATION CONTAINED IN THIS DRAWING IS THE SOLE PROPERTY OF LASERLINC, INC. ANY REPRODUCTION IN PART OR AS A WHOLE WITHOUT THE WRITTEN PERMISSION OF LASERLINC, INC IS PROHIBITED. | MATERIAL LL | 63 RA SURFACE FINISH ALL FEATURES MUST MEET SPECIFICATION AFTER PLATING BEFORE POWDER-COAT IF PLATED OR POWDER-COATED SEE FINISH | | SIZE B | DWG. NO. 0430-0000-28 | REV F |
| | DO NOT SCALE DRAWING | SCALE: 1:1 | | SHEET 3 OF 3 | | |